

UC-NRLF



SB 108 464

ON THE
SAFEGUARDING OF LIFE
IN THEATRES

FREEMAN

2
DEC 7 1906

LIBRARY
OF THE
UNIVERSITY OF CALIFORNIA.

GIFT OF

Charles A. Crane & John R. Freeman

Class

On the day following the burning of the Iroquois Theater, a citizen of Chicago, who had lost two little nieces in the fire, asked a friend, who for many years had made fire prevention a study, to go to Chicago immediately to investigate means for rendering such fearful disasters impossible.

The work was undertaken earnestly, in the hope that good might be accomplished, and this report was presented at a meeting of one of the great national engineering societies in order to give publicity and to invite discussion.

The address has been reprinted in the present form, that its conclusions may be brought to the attention of some who might not see them in the "Transactions" of an engineering society.

ON THE
SAFEGUARDING OF LIFE
IN
THEATERS

BEING A STUDY FROM THE STANDPOINT OF AN
ENGINEER

BY

JOHN R. FREEMAN

PRESIDENT AMERICAN SOCIETY
OF MECHANICAL ENGINEERS

AN ADDRESS MADE AT THE OPENING OF THE ANNUAL
MEETING OF THE SOCIETY IN NEW YORK CITY

DECEMBER 4, 1905



REPRINTED
FROM THE
TRANSACTIONS OF THE SOCIETY

1906

TH 9445

T3F7

WITH THE COMPLIMENTS OF
CHARLES R. CRANE, CHICAGO, ILL.
AND
JOHN R. FREEMAN, PROVIDENCE, R.I.

FOREWORD

The results which are set forth at length in these hundred pages may be briefly summed up as follows :

1. It is not a difficult or an expensive matter to provide safeguards such that a theater or other hall of public assembly may be made reasonably safe.
2. In the great theater fires of history the loss of life has commonly resulted from the rapid spread of flame on a stage covered with scenery, followed within two or three minutes by an outpouring of suffocating smoke through the proscenium arch into the top of the auditorium, before those in the galleries could escape. Death has come chiefly to those in the balconies, and often within less than five minutes of the first flame.

The three great safeguards are found to be:

1. The providing of ample, automatic, quick-opening smoke vents over the stage.
2. The thorough equipment of the stage with automatic sprinklers by means of which the action of the heat will promptly release, over the burning scenery, a rainfall tenfold heavier than the heaviest thunder-shower, drenching the scenery and extinguishing the flames.
3. The providing of especially ample exits and stairways from the gallery.
4. The foregoing transcend all other requirements.

The fire proofing or flame proofing of scenery is found to be of doubtful value under the practical conditions of use.

The so-called fireproof paints are of very small fire-retarding value.

The asbestos curtain is found to possess much less endurance against heat and flame than had been supposed.

The steel curtain covered with non-conductor on the stage side is far better than the asbestos curtain, but may give trouble in lowering or may permit large quantities of suffocating gas to be forced into the auditorium around its edges.

5. Dry-powder fire-extinguishers and hand grenades are likely to prove worse than useless, by promoting waste of valuable time.



No. 1096.*

ON THE SAFEGUARDING OF LIFE IN THEATERS.

A STUDY FROM THE STANDPOINT OF AN ENGINEER.

BY JOHN R. FREEMAN, PROVIDENCE, R. I.
(Member of the Society.)

Custom has decreed that the President of this Society should choose his subject for the opening address of our winter meeting from within some field of his own special work, and that the address should be either a historical review, or an effort to lead the thought of the evening into some useful line of advance in applied science; and so I bring to you a topic that has been much in my thought for two years past, and in one corner of the field of fire protection, to which I have devoted a portion of my time for twenty years.

It is a fair and moderate statement that the present practice of the art of fire prevention, as applied to theaters and buildings of public congregation, is from ten to twenty years behind the fire protection of the best industrial works, and true that the fire hazard to theater property in general, as measured by a comparison of insurance rates, is ten to twenty times as great for the modern theater as for the modern factory.†

* Presented at the New York meeting (December, 1905) of the American Society of Mechanical Engineers, and forming part of Volume 27 of the *Transactions*.

† At the time of the Iroquois fire the average cost of insurance per year on the principal Chicago theaters was, on buildings 3.7 per cent., on furnishings and fixtures 4.3 per cent., on scenery 4.7 per cent.

On the best fireproof theater buildings in Chicago it was about 1 per cent., with 2 per cent. on fixtures, furnishings, and scenery therein. On some of the more hazardous theater structures in Chicago the rates were 6 per cent. and even 7 per cent. per year. The same insurance companies that insure these theaters will insure a strictly first-class cotton mill, or even a first-class woodworking or rubber factory, at $\frac{1}{10}$ to $\frac{1}{5}$ of 1 per cent. per year, when thoroughly protected by automatic sprinklers, etc.

We must bear in mind that a comparison of insurance rates, while an excellent guide, is not a complete or accurate basis for a comparison of safety to life in

All of this is unnecessary. It is a wrong against the public that should be righted. The actual fire hazard at the theater can be made smaller than that of the factory by well-proved means, the cost of which is not extravagant. The safeguards needed are mostly simple; the main features of some of them are already worked out and well proved within the great factories which you engineers build and manage; the additional safeguards required to be worked out, or adjusted for this special case—the automatic smoke vents—the safe proscenium curtain—the safe warming and ventilation—the proper arrangement of automatic sprinklers in stage and dressing-rooms and storerooms, are within the field of the Mechanical Engineer, and are mostly simple problems when serious attention and skill are once directed to them.

As a society of engineers, we have a precedent for giving our time to this study in the investigation made by the Austrian Society of Engineers after the burning of the Ring Theater in Vienna, and republished by them after the burning of the Iroquois.

In the great factories of New England first, and more recently in those of the Middle States and Middle West, all represented largely in our membership, there have been slowly worked out the most advanced methods of fire prevention that are anywhere to be found. This safety of the slow-burning American factory has come first through an appreciation of the danger and then a study by one engineer after another of how to meet it; then a conscientious attention to perfection of detail, and then an education of the average workman about the place into the requirements for safety.

In the course of my own studies of the theater and auditorium problem, I have seen almost everywhere conditions affecting the safety of life that would not be tolerated by the managers of our best industrial works, and all from simple failure to know or to give attention.

For example, I have seen in one of the best New York theaters the wedge-shaped space beneath the sloping floor of the auditorium used as a storeroom for trunks and properties. This room was also the plenum chamber for the ventilation. Suppose that rats and matches, spontaneous ignition of oily material, or any of

different theaters, for the questions of accident or death to audience and actors are mostly settled within the first five minutes after fire breaks out, while the per cent. of damage, that concerns the fire underwriter, may be in suspense for an hour or more.

the obscure but frequent causes should start even a slow, smouldering fire in this room. Why is it not foreseen that the smoke rising through the air ducts in the floor might throw the audience into a panic and cause great loss of life?

In one of the most famous halls in America I found the portable wooden flooring, used sometimes to level up and transform the main seating space into a ballroom, stored in a dark passageway, which formed the main air chamber between the heating coils and the concert hall, all thus kiln-dried to perfection, and when I showed it to the manager and to an intelligent aldermanic committee and urged its immediate removal, they saw no danger and thought me hypercritical, and could not even see that automatic sprinklers would be of use in such a concealed storage space.

In Chicago, within a few months after the appalling disaster at the Iroquois Theater, the aldermen rescinded the rule calling for automatic sprinklers over the stages and rigging lofts* of the theaters because the managers believed they "wouldn't do any good," and "might start a panic should one happen to open prematurely." Every factory manager or mill engineer in this audience will admit the absurdity of such a statement.

In Boston, the law still accepts the non-automatic sprinkler pipe to be opened by hand, a device which has now been almost totally discarded in factory fire protection in favor of the automatic.

Most dangerous of all, I have found behind the scenes and in the mechanics' rooms a lack of the scrupulous neatness and order that characterizes a modern, well-organized factory; have found a multitude of dark, concealed spaces used as catch-alls, and an apparent lack of appreciation by owner and architect that *a flood of daylight in storerooms, workrooms and dressing-rooms is the best of all safeguards*, by making dirt, disorder and dangerous rubbish conspicuous. While there are notable exceptions, the atmosphere of the theater is largely of show and tinsel, and this contributes to the less thoroughgoing standards of neatness and completeness than in the factory.

We cannot leave it to the underwriter to make the theater safe against fire. The able president of one of the largest insurance companies has said to me, "As an individual, I would be very glad to see the theaters safe for the public which patronizes them, but

* They are insisted on in the mechanics' rooms, and in other places far less dangerous to the audience.

as an underwriter *I charge for the hazard as I find it*, and need not care particularly whether the rate is one per cent. or five per cent." He tells me, too, that on the whole the theater class at current rates is profitable underwriting.

We cannot leave it with the framing of a good building law. The same underwriter also said to me, "The City New York has a pretty good building law, yet the city is full of theaters that are unsafe, some of them constructed since the building law went into effect." The Chicago Building Law required automatic sprinklers over the stage; until after the Iroquois, not one had ever been put in. Then, in the effort to perfect the enforcement of the law, they cut out its requirement for sprinklers over the stage!

How can we transfer the care and the precautions of the modern factory to the modern theater? How can we bring the manager, the architect, and the official guardians of public safety—the fire chiefs and the public inspectors of buildings—to understand and introduce the well-proved safeguards, and to be critical about that perfection of detail on which safety depends? How can we bring the public to demand these things?

Our fellow-member, Mr. Gerhard, presented some of these matters admirably some years ago in a series of popular talks which he recast into a most useful and suggestive little book on Theater Fires.

A German engineer, Herr August Foelsch, of Hamburg and Vienna, began in 1869 to collect statistics of theater fires, and up to the time of his death had collected records of over 500. This list has been extended by Mr. E. O. Sachs, a London architect, until it contains some account of 1,000 theater fires that have happened in various parts of the world within about 100 years. The American engineer, Hexamer, has also added useful contributions to this record. These figures are impressive, but *they teach far less than a full study of a few of the notable examples.*

The Example of the Iroquois.

I first became actively interested in this question by the burning of the Iroquois Theater at Chicago a little less than two years ago. A prominent manufacturer, two of whose little nieces were among the nearly 600 people that perished, wired me to come over to Chicago and investigate; in a noble spirit he said, not for the

purpose of fixing the blame, but to help us find out how such fearful disasters can be prevented.

I examined the structure before any of the wreckage had been moved, listened to evidence before the coroner's inquest, counseled with the mayor and committee of the Board of Aldermen, questioned eye-witnesses, visited Chicago repeatedly, and for several months devoted to this study all of the time that I could get release from business, and inspected many other theaters in the effort to reach a clearer understanding of their special hazards.

This fire at the Iroquois Theater occurred at a Wednesday afternoon matinee, in the midst of the holiday season, when the theatre was crowded, largely with pleasure parties of women and children.

A spectacular play was being given; the amount of scenery was uncommonly large; the fire was caused by a spark from a portable electric arc light, known as "spot light"—used to throw a strong light on a special group—which set fire to one of the draperies. The fire spread in the hanging sheets of scenery with great rapidity and it is probable that in from one to two minutes the great mass of scenery on the stage was in flames. Meanwhile an unsuccessful attempt was made to lower the asbestos curtain—the leading comedian came forward and urged the audience to keep their seats. A door, opened by the escaping actors, let a great rush of air inward—this together with the expansion of the air in the top of the stage space by the heat drove the flames out under the proscenium arch into the upper part of the auditorium. Here was instant discovery—cool, prompt action by the theater staff. There was, perhaps, a momentary delay in sounding the public fire alarm, but with admirable promptness the chief of the public Fire Department and an efficient force of firemen were on the ground within little more than five minutes from the first alarm—we can never hope for prompter or better service from a public fire department—but even by that short time *most of the victims had already become suffocated.*

Some of the cooler headed, who followed the maxim for safety, "Remain in your seat and avoid crushing at the exit," were suffocated in the gallery where they sat.

Out of an audience of about 1,830, there were 581 killed, or 32 per cent., and it is said about 250 more were injured.

Of those killed, about 400 occupied the gallery, or 70 per cent. of those in the gallery perished; and about 125 occupied the balcony,

or 30 per cent. of those in the balcony perished. Of those who occupied the floor not more than 7 were killed, and most of these deaths, it is said, were caused by persons jumping from the gallery.

Suffocation was the main cause of death. The underwriters' loss was small as theater fires go.

What has been called the irony of fate is found in the fact that the scene of this appalling disaster was the newest of Chicago's theaters, a building of fireproof construction that justified the name so far as the building itself was concerned—a theater that structurally, perhaps, had no superior in this country or in the world. Little except scenery, decorations and upholstery was damaged by the fierce fire.

It is true that there had been shameful neglect in important details of fitting up, that fire hose on the stage had been delayed, and that fire pails and soda-water fire-extinguishers were absent, and that the ventilating skylights over the stage were blocked so they could not slide open, and that exits were poorly marked; but I have come to believe that had these all been in the condition commonly found in American theaters, the result of this fire might have still been appalling, and it is because I am sure the great lessons of this and the other great theater catastrophes have not been properly heeded that I speak on this topic to-night.

The great lesson of the Iroquois centers around the sudden outbreak, the rapid progress of the fire over the stage, and the fact that most of the deaths occurred within five minutes of the first flame; that death came to nearly all of those who had seats in the gallery, while nearly all of those on the floor escaped.

The great lesson of the Iroquois fire was only a repetition of a lesson that has been given several times before and each time forgotten.

The recurring formula is:

- (1) A stage crowded with scenery.
- (2) The sudden spread of the flames over this scenery.
- (3) The opening of a door in the rear of the stage, an inrush of air.
- (4) Scant smoke vents over the stage, an outburst of smoke under the proscenium arch.
- (5) Death to those in the galleries.

In 1881, at the Ring Theater disaster in Vienna, with about 1800 in the audience, careless lighting ignited a "hanging border;"

a large door in the rear of stage was opened, letting in a blast of air that drove the smoke through the proscenium arch; the iron curtain could not be lowered; special exit doors were found locked; 450 were killed, *mostly in the upper gallery.*

In 1887, at Exeter, England, fire caught on a stage crowded with scenery. *Within about five minutes* from the outbreak of the fire, 200 were killed, *mostly in the upper gallery.*

In 1876, at Conway's Theater, Brooklyn, N. Y., the stage was crowded with scenery; a border caught fire; the blast of suffocating smoke was increased by the opening of large doors in the rear of stage; about 300 were killed, *all in the upper gallery.*

Note the suddenness, the suffocation, and that *the fatalities are nearly all in the galleries* and that these old descriptions will each tell the story of the Iroquois.

In 1903, at the Iroquois Theater, Chicago, the stage was crowded with scenery. A piece of hanging scenery was set on fire by an electric light. A door at the rear of stage was opened, increasing the blast of suffocating smoke sent into the auditorium. Within from five to ten minutes about 580 were killed, mostly in the upper gallery. Substantially, all of those who had seats on the floor got out alive. Out of about 900 who were in the gallery and the balcony only about 300 got out alive.

The obvious suggestion might be, make the scenery incombustible, and the popular belief taken in from old text-books is that this is a simple matter. Of its difficulties and uncertainties, we will speak later. Suffice it for the moment to say that notwithstanding the paternal care with which the government in England and on the Continent looks after all matters of public safety, and notwithstanding the many recipes in French and English publications for making fabrics incombustible, none of these foreign governments, so far as I can learn, specify that scenery shall be subjected to any process of flame-proofing.

We may make scenery less easily inflammable, so that a match or an electric spark will not ignite the canvas or gauze, but *the efficient fire-proofing of scenery, so that it will not all burn up if a fire once gets well started on the stage, is simply impracticable.* Of all this we will speak later.

The scenery which burned so rapidly at the Iroquois was all made in England, and was first used under the supervision of English law, in the Drury Lane Theater, in London.

We will in briefest manner possible discuss a few of the chief features of the theater risk and means for meeting them.

The Fuel.

The amount of combustible material on the stage in a great spectacular piece is surprisingly large. On the Iroquois stage at the time of the fire there was more than ten thousand square yards of canvas, or two and one-half acres, and in addition about

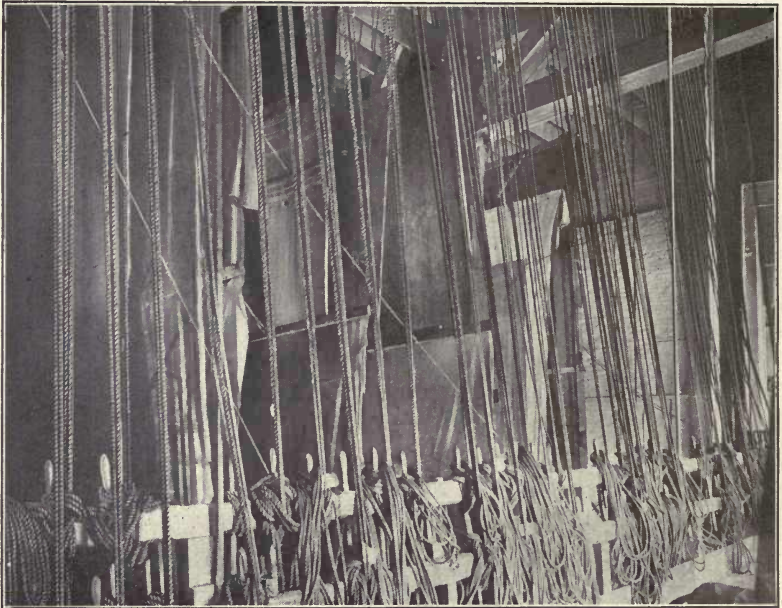

FIG. 1.—A TYPICAL VIEW OVER A THEATER STAGE, ABOVE THE LEVEL OF THE PROSCENIUM ARCH, SHOWING THE CANVAS SCENERY, THE ROPES BY WHICH IT IS RAISED AND LOWERED, AND THE "PIN-RAIL" ON WHICH THESE ROPES ARE FASTENED.

three thousand square yards, or half an acre, of gauze. To hang this required nearly eleven miles in length of $\frac{5}{8}$ -inch manila rope, and in the frames, battens, braces, profiles and set pieces, the stage carpenter of the Iroquois tells me, after making careful estimate, that there was about eight thousand square feet of white pine lumber. The total weight of this fuel was more than ten tons, all dry as tinder, and all set or hung in a way to give the quickest possible exposure and spread to the flames.

Figs. 1 and 2 will give some idea of how this is hung.

The paints used by the scene painter are not dangerous. They are almost entirely mineral substances put on with water and glue, and they tend to make the fabric a little less readily combustible.

It is very rare that so much scenery is found upon a stage; but if, as is more common, it were only one-fourth part as much as at the Iroquois, it is plain that the fuel supply is sufficient to send out an enormous volume of suffocating gas. Indeed, I have com-

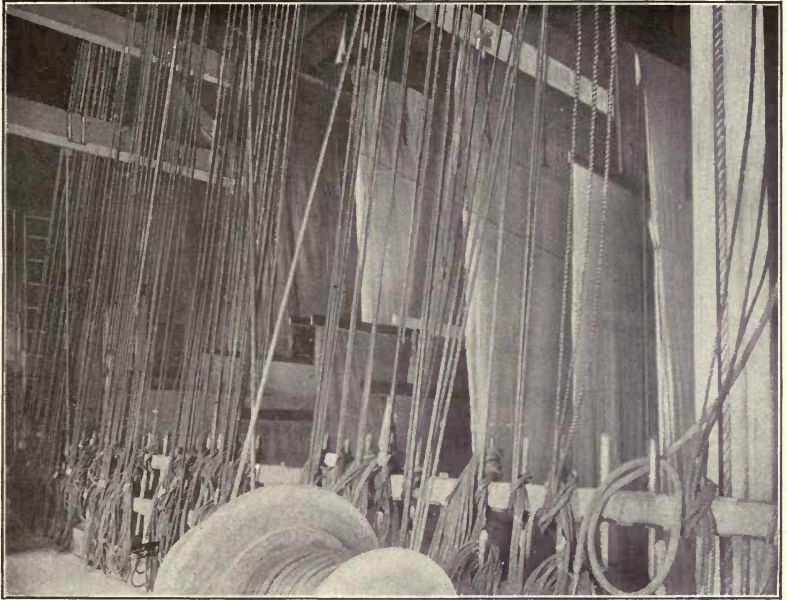

FIG. 2.—ANOTHER TYPICAL "HANGING-LOFT" OVER A THEATER STAGE. NOTE HOW THE NECESSARY ARRANGEMENT OF THE SHEETS OF CANVAS FAVORS RAPID BURNING.

puted that merely the quick burning of this one hundred and sixty pounds of gauze that hung over the Iroquois stage would heat a volume of air equal to that contained in the large space of the hanging loft above the level of the proscenium arch to 1,000 degrees Fahrenheit.

There is good testimony to the effect that in the Iroquois fire only about two minutes' time elapsed after the first spark until all the upper scenery was in flames. Only from three to four minutes' time elapsed before the large space of the hanging loft was so filled with fire that the flames and smoke rolled out be-

neath the proscenium arch into the top of the auditorium; inside of five minutes from the first spark came suffocation and death.

The foremost problem of safeguarding life in theaters is to give prompt and certain vent to this smoke and suffocating gas elsewhere than through the proscenium arch.

CONCERNING THE SMOKE VENTS.

The ordinary construction, with a high spacious chamber for the hanging loft above the level of the proscenium arch, is such

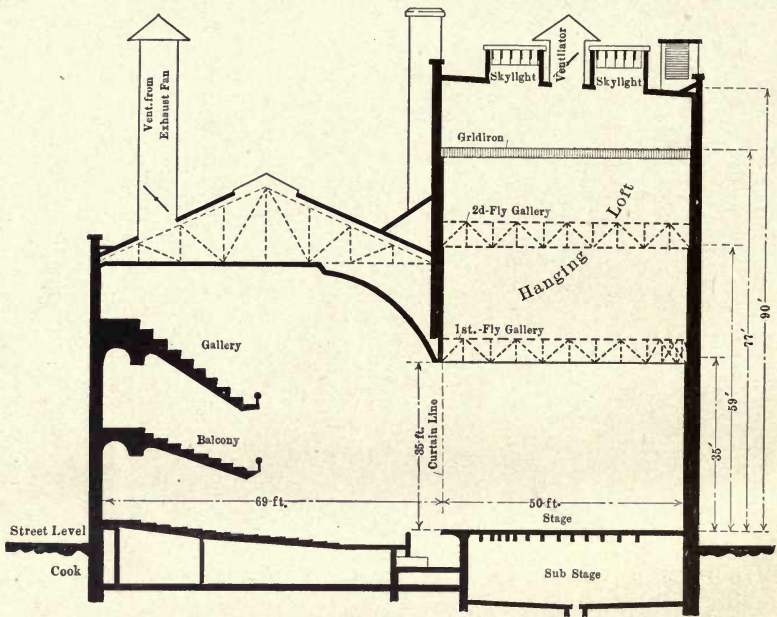

FIG. 3.

that it is a simple matter structurally to keep this fire and smoke out of the auditorium, and no matter how great the mass of flaming scenery, a smoke vent of one-eighth or one-tenth the area of the stage, if instantly opened, would probably have saved all of this terrible suffocation at Chicago, at Exeter, at Brooklyn and at Vienna. *This remedy is so simple, so sure and so cheap that it is a crime not to apply it.*

A thoroughly good automatic smoke vent will do more for the

safety of the public than all of the remaining provisions of the most elaborate building law.

As yet, not one theater in ten has it!

Fig. 3 shows a cross section of the Iroquois through auditorium and stage. The form is typical and about the same in all first-class theaters. To one who has not been behind the scenes and climbed up to the gridiron, the surprising thing is the great head room, commonly seventy feet from stage to gridiron and eighty or sometimes ninety feet from floor to roof, and necessarily more than double the height of the proscenium arch, into which are hoisted the great sheets of canvas on which the scenes are painted.

The conditions are plainly similar to that of the fireplace in our living room, magnified ten or twenty diameters. Note how admirably the high space over the stage, screened by the arch, is adapted to give the best of chimney draft, and not give us a smoky fireplace. The roaring fire on our hearth sends ninety or ninety-five per cent. of its heat up the chimney and gives out no smoke into the room, if only the chimney be properly designed and the damper open. An ordinary rule is to make the throat of the chimney at least one-tenth the area of the fireplace opening, or it may be stated that the space through the damper should be one-eighth the area of the hearth, and *when we simply provide an adequate chimney area and a damper that will surely open, we shall have adopted a safeguard that would have saved four-fifths of those who perished at the Iroquois*, regardless of defective curtain, defective exits and absence of fire hose on the stage.

In a way, it has been long recognized there should be a large ventilator over the stage, and one city has copied from another the building law that in the case of New York City reads as follows:

“There shall be provided over the stage metal skylights of a combined area of at least one-eighth the area of the stage, fitted with sliding sash and glazed with double thick sheet glass . . . the whole of which skylight shall be so constructed as to open instantly on the cutting or burning of a hempen cord . . . Immediately underneath the glass of said skylight there shall be wire netting. . . .” etc.

The evident purpose of the thin glass is to cover the vent with something that will break out under heat if the mechanism for sliding the cover off fails. The wire netting is to catch any piece of broken glass from falling to the stage.

The building law of the London County Council reads much the same, save that its ratio is one-tenth, and perhaps that ordinance is where the rule began.

Some of the leading American cities make the proportion one-tenth. In the revised Chicago ordinance, notwithstanding their fearful lesson, they are content with ventilators of one-twentieth the net area of the stage, because, as one of the Aldermanic Committee gravely assured me, "If the area was made too large, it might cause a down draft."—What stupidity!

The idea of a large ventilator expressed in these rules is all right, but the execution is commonly all wrong, and needs some good engineering to provide a design of damper with careful details that will be sure to work. Note the antiquated, good-for-nothing suggestion of the "burning of a hempen cord," when fusible links have been used on the fire doors in your factories for twenty years! There is no good reason to expect the hempen cord in this position in smoky atmosphere from which oxygen had been largely removed would burn off until after a majority of the people in the gallery had been suffocated.

And in one of the newest and best of the New York theaters I found the ventilator had a broad sheet of heavy canvas laced tightly across its opening with marline, because, as the stage carpenter told me, "the cracks around the ventilator let in too much cold air." No building inspector had objected, and the carpenter could not be made to see any danger. "It would burn off in any bad fire," he said. So it might, but not until the people in the gallery were mostly dead.

The requirement of thin glass in the building law is well meant, but it would be too slow in breaking out. Remember how quickly unconsciousness of suffocation comes in an atmosphere of smoke. The wire netting called for *is a positive danger*, as often applied.

One of the most experienced theater managers in America told me frankly that he knew the smoke vents on the theater which he then occupied would probably not open in winter unless a man should first pry them loose with an iron bar; but, said he, "I have not heretofore seen anything better," and so after the Iroquois he had set his stage carpenter at work to invent something.

Doubtless, there are good smoke vents here and there that have been designed and built with skill and conscience, for the problem is not so very difficult, but I have not yet seen one of these vitally important pieces of apparatus in which the design

proper specification of "a vent of ample area that will be sure to open wide, instantly, without human intervention, and that cannot be stopped by warping, settlement, obstruction, frost, snow, rust, dirt, or ordinary neglect."

I do not know who first fixed this ratio of one-tenth for size of ventilator, the same figure that appears in the old rule of the London County Council. Its author may have built wiser than he knew, or may have taken it from the well-proved ratio of the common home fireplace chimney. It works out as safe when computed mathematically on theoretic grounds from the uncertain data. The material is so favorably disposed for ignition that the rapidity of combustion is largely a question of the air supply.

I am led by computation and precedent and the need of some factor of safety, to concur in the wisdom of the ratio of one-eighth or one-tenth, as already specified by the building laws of the great majority of our American cities, and I believe it wise to base it upon the gross area of the stage floor rather than upon proscenium opening or cubical contents of the stage.

I have seen here in New York, in a recent theater, a case where the inspector had, perhaps temporarily, forgotten the wording of the law and figured it on the area directly in behind the curtain, omitting much of the floor space at the sides. This is wrong because, given a large stage, there is a well-proved tendency to permit an unnecessarily large amount of combustible material upon it, and it not infrequently happens that the scenery of next week's new attraction may be found stored at the side and rear during the Saturday night performance.

I was earnestly desirous of making some practical tests in the Iroquois, for the additional flames could have caused no injury beyond that already wrought, and the practical demonstration which I am confident would have been given regarding the efficiency of automatic sprinklers and proper smoke vents would have hastened their general introduction. Of course such tests would have been made under greatest precautions and with city fire department at hand in force, but while many of the most important interests readily consented a few of those owning surrounding property objected.

The Austrian Experiments of 1885.

Following the great theater fire in Vienna, a committee of the Austrian Society of Engineers (Vereines der Techniker, in Ober

Oesterreich) built a model of the Ring Theatre on one-tenth of its lineal scale, which thus contained only one-one-thousandth of the cubic contents of the original, and made many tests and experiments.

The experiments were divided into two groups, the first comprising those in which no ventilators were opened over the stage, while in each of the experiments of the second group two ventilators were opened, having a combined area which according to the scale of their drawing I find was very nearly one-tenth of the area of the stage. In the first series of tests made by igniting sheets of paper hung to represent the scenery, but containing proportionally far less combustible material than is often hung on a theater stage, they found that the expansion of the air caused by the heat *quickly forced the curtain outward from the proscenium arch*, and within about twenty seconds from lighting the fire, this heating of the air produced an excess of atmospheric pressure, much greater than that of the ordinary pressure of city gas, thereby explaining why it was that the lights in the Ring Theater became so quickly extinguished after the outburst of the fire.

In the second series of these Austrian experiments, their models of the ventilating shafts were closed by sheets of paper, and as soon as these smoke vents burned open, all excess of air pressure disappeared from the auditorium, and indeed, the updraft drew the proscenium curtain inward over the stage.

During these experiments an unexpected warning was given against covering smoke vents by wire screens, for it was found the flying bits of charred paper carried up by the draft almost completely closed them. To show how little this warning of the Austrian Society of Engineers has become incorporated in current practice, I may call attention to the building law of New York City, which *requires* that underneath all of these skylight openings designed as smoke vents, wire netting must be stretched; the law apparently never considering how quickly this will become so clogged as to destroy in large part the utility of the smoke vent. At my visit to the remodeled Iroquois, I found the openings in their new ventilating shafts screened by wire netting in a way that would probably *within a minute's time put them into a condition of uselessness* because of the fragments of burning cloth and embers with which they would be immediately covered under the strong updraft, all of course with approval of architect and building inspector!

The committee of the Austrian Society of Engineers concluded that the outburst of flame and smoke into the upper part of the auditorium and the extinguishment of gas lights in a theater *could all be prevented by providing adequate smoke vents* over the stage, and places these smoke vents as the feature of first import in safeguarding life in theaters, and says that without them emergency exits and fire curtains will be of no avail; and in this conclusion I most heartily concur, for I had independently reached it from my investigations following the Iroquois disaster, prior to learning of the experiments of the Austrian engineers.

Regarding the mechanical construction of these smoke vents, the Austrian committee says, "It is necessary that these be opened instantly upon the outbreak of the fire; mechanical contrivances of iron to be operated by human means will certainly fail, for, according to all experiences in theater fires thus far, fright on the part of the employees prevents the use of such arrangements." They warned against automatic contrivances whose action may be interfered with in consequence of rust or expansion by heat, and against sheet iron valves falling inward by their own weight, which might be restrained from falling open by the excess of pressure due to updraft, and finally recommended that these shafts be closed by a quickly combustible tissue of hemp or jute covered with varnish or celluloid, and with a hole about one and one-half inches in diameter in the center to invite quicker ignition. Our Austrian friends were unfamiliar with the American fusible-solder link, which is certainly quicker and safer and in every way far more practical than any such tissue of varnished hemp.*

**Austrian Experiments of 1905.*

While revising the proofs of the above for publication in the yearly volume, report comes of a second series of tests on a somewhat larger scale, made on and about Nov. 22, 1905, in Vienna at the expense of the Austrian government, on recommendation of the Austrian Engineers and Architects Association. From the brief preliminary report in Eng. News of Jan. 18, 1906, the following is taken:

The model theater, constructed of reinforced concrete especially for these tests, had a stage 24.6 ft. wide, 19.7 ft. deep, 25.3 ft. high, with a proscenium opening 11 ft. wide and 8.5 ft. high. The auditorium was 18 ft. wide, 23 ft. deep, 15.4 ft. high, or in general had about $\frac{1}{3}$ the linear dimensions of the ordinary theater, and therefore about $\frac{1}{27}$ of its cubic capacity.

The tests made by burning old scenery and sheets of paper, representing proportionally the amount of combustible for two performances, showed that with smoke vents of total area of 11 per cent. of the stage area opened, the smoke ascended through these vents over the stage with no suggestion of danger to the persons in the auditorium, except that near the proscenium opening the heat was somewhat severe.

Fusible Links for Opening Smoke Vents.

These links have been in common use on automatic fire shutters and fire doors in our factories for twenty years. Three types of these links are shown in Fig. 4. Each is reliable,

On the other hand, in tests with stage vents closed and curtain down, it was bulged out toward the audience and lifted from the floor at the bottom, and the auditorium was soon filled with smoke.

In a later experiment with sprinklers spraying the fire, on opening a door or ventilator in the auditorium gallery some steam and hot gases were drawn into the auditorium, notwithstanding the stage smoke vents were open.

As a whole these tests again demonstrated the importance and the remarkable efficiency of a smoke vent over the stage, of about 11 per cent. of its area.

It is of interest to note that these two sets of Austrian experiments have given a complete answer to two of the puzzling questions of the fire at the Ring Theatre. At the inquest the man was sought who was supposed to have turned off the gas from fear of an explosion, thus leaving the house in darkness while the audience and actors were struggling to escape; he was not found. Both series of these experiments on the theater models show that a back pressure of air in the auditorium more than sufficient to force the gas back in the pipes, and thus extinguish the lights, was produced by the rapid expansion of the air over the stage due to the heat of the fire. Indeed, this quick back pressure was found sufficient to account for the bursting open of the large scene door at the back, which it had been supposed was opened inadvisedly, thereby causing the draft which blew the suffocating smoke into the auditorium.

I have not the full report of these later tests at hand. In studying the reports of the Austrian tests of 1885, I am unable to believe that the back pressures due to expansion of air are ever likely to be so large in an actual theater fire as those developed in the model tests and carefully measured on the manometers. I saw no evidence of so great pressures at the Iroquois, and failed to find evidence in the testimony of the eye-witnesses, although the conditions were favorable for very rapid burning. I have no doubt there may have been sufficient pressure momentarily, at the end of the first half-minute or full minute, to blow the curtain strongly outward, but the absence of scorching of wood and textiles around the opened rear stage door shows conclusively that after this was opened the air current there was continuously inward.

In the Austrian experiments of 1885, with smoke vents closed, air pressures were developed momentarily at from 20 to 30 seconds after lighting the fire—as great as $\frac{1}{4}$ lb. per square inch, or equivalent to 5 or 7 inches of water column or 32 to 38 lbs. per square foot! With smoke vents covered by thin paper which quickly burned open the excess of air pressure on the stage was only momentarily equivalent to 0.07 inch of water column, with no excess observed in the auditorium.

The preliminary reports of the Austrian experiments of 1905 show that with smoke vents closed, even a steel proscenium curtain was no sufficient safeguard for the audience. The air pressure due to expansion held it from lowering promptly, and when lowered the suffocating gas and flames were driven past its loosely fitting edges into the auditorium. With smoke vents open a proscenium curtain was hardly necessary.

practical and successful, as proved by years of use. They can be obtained from any of the manufacturers of automatic sprinklers.

It is strange almost beyond belief how slowly and scantily these have found their way into the fire protection of theaters.

These links melt open at about one hundred and sixty-two de-

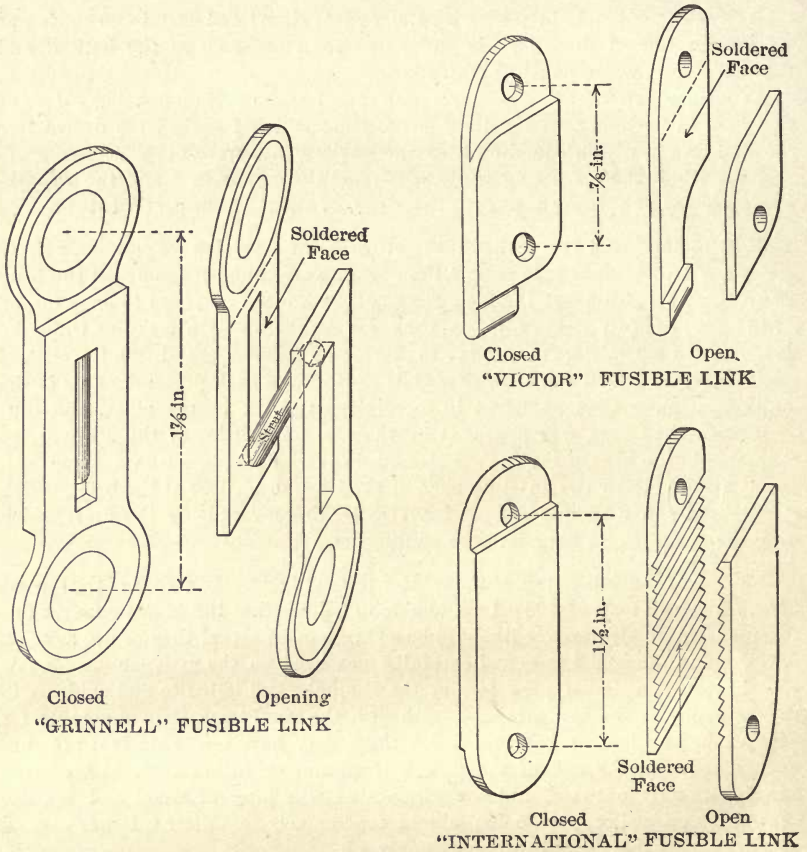

FIG. 4.—FUSIBLE LINKS FOR FIRE PROTECTION.
SCALE, FULL SIZE.

grees Fahrenheit, and thus will open long before flame reaches them. Their cost is trifling. They are stamped out of sheet brass, soldered with "fusible solder," the formula for the 162° F. alloy being

Tin.....	12	per cent.
Lead	25	" "
Bismuth.....	50	" "
Cadmium.....	13	" "
Total.....	100	" "

Links like those shown in Fig. 4, tested to immediate rupture, will break under a load of about two hundred to five hundred pounds, but can be trusted to sustain continuously a load of only about fifty to one hundred pounds. Our tests show that the solder becomes somewhat weaker in warm air than in cool air. Probably in an atmosphere of 100° F. the links would safely sustain 10 per cent. to 20 per cent. less load than in an atmosphere at 60° to 70° F.

All of the known solders that fuse at low temperature are subject to stretching or "cold flow" under long-continued loads, unless these loads are made extremely small, and one of the most important features in the design of any such link is to make the direct stress upon the solder small and in tension over a large area, rather than by shear.

The links shown in Fig. 4 will open with about the same promptness as an automatic sprinkler. In a test oven, immersed in an atmosphere of four hundred degrees Fahrenheit, these various forms of link open in 35 to 100 seconds; in five hundred degrees, in 25 to 75 seconds.

At top of rigging loft over a fire like that on the Iroquois stage, fusible links probably would open within 30 to 60 seconds after the blaze got a good start, and in ample time before the smoke would burst out under the proscenium arch. There is ample space in the hanging loft to pocket the smoke for the first minute or two. At the Iroquois fire statements of eye-witnesses indicate that it was probably fully two minutes before the smoke rolled out into the auditorium. I was surprised to find on measurement of the Iroquois plans that the volume of air space above the level of the arch was greater over the stage than over the auditorium.

The sensitiveness of these links or their quickness of action under moderate degrees of heat depends on the thinness of the mass of metal to be warmed up, and therefore on the rapidity with which it absorbs heat enough to melt the solder. These two characteristics—the weakness of the fusible solder under long-continued strain, and the necessity for rapid absorption of heat, limit the size and strength of fusible link that can be employed; but it is easy to so design the connections that the strain will be about fifty pounds, thus large enough to override dust, rust and petty derangements and small enough to be within the capacity of the fusible link. In many situations a link is desired of such form

and size that when inserted in a rope it can run over the ordinary pulley.

Imperfections of Smoke-Vent Design.

Concerning the design of smoke vents, those that I have seen in actual use have been, with hardly an exception, imperfect pieces of mechanical design. At certain of the most recent New York theaters I have found the type which appears to be the favorite for meeting the New York building law, set with such a clearance as to give a very unnecessary degree of ventilation, which tempts the theater mechanic to stop the draft by some means that may prove dangerous. It is, moreover, so heavy and unwieldy that it cannot be frequently tested by opening and closing, and to wait for the burning of a hempen cord to open a device of this kind should be regarded as criminal negligence when it can be done so much better and quicker by the automatic fusible link.

Smoke-Vent Designs by the Author.

To meet the proper suggestion that one should not merely criticise without presenting a better device, and as a means of illustrating that the problem can be solved along various lines of design, I have worked out two models, shown in the accompanying drawings. I am certain that with the experience to be gained in constructing one after another, these designs could be improved upon. It is desirable that the total smoke-vent area of one-eighth or one-tenth the stage be subdivided into four independent units for convenience in size and for the further safeguard that should one stick there are three others left.

The fundamental requirements for a theatre smoke vent are:

1st. **Absolute certainty** of opening by force of gravity, in spite of neglect, rust, dirt, frost, snow, or expansion by heat, twisting or warping of the framework.

2d. **Quickness** of opening to be secured by automatic links of the thinnest metal practicable, and also by controlling the doors by a cord run down to the prompter's stand and to the station of the stage fire-guard.

3d. **Simplicity and massiveness** of the operative mechanism of the smoke vent. This should be designed not as a watch-maker would build it, but more according to the standards of railroad service or rolling-mill practice. The counterpoise weights should be heavy, and a constant tension on the re-

lease cord of upward of thirty or forty pounds so that rust, cobwebs or temperature changes may not be of noticeable effect in the resistance to be overcome.

4th. **Daily Tests.**—It should be of such form that it can be tested daily, or at least at the weekly inspection, by partially opening it, preferably closing it again by means of the cord running to the prompter's stand. It may perhaps add to the safety if it is of such design that it can be used whenever needed for the ordinary ventilation of the stage, summer or winter, rain or shine, thereby keeping it under constant view and bringing into immediate notice any difficulty about its opening or lack of repair.

In the first of these designs submitted, shown in Figs. 5, 5a, 5b,

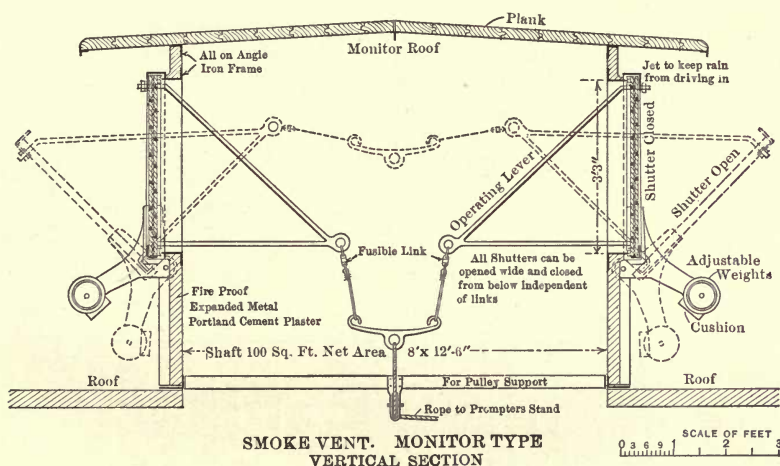
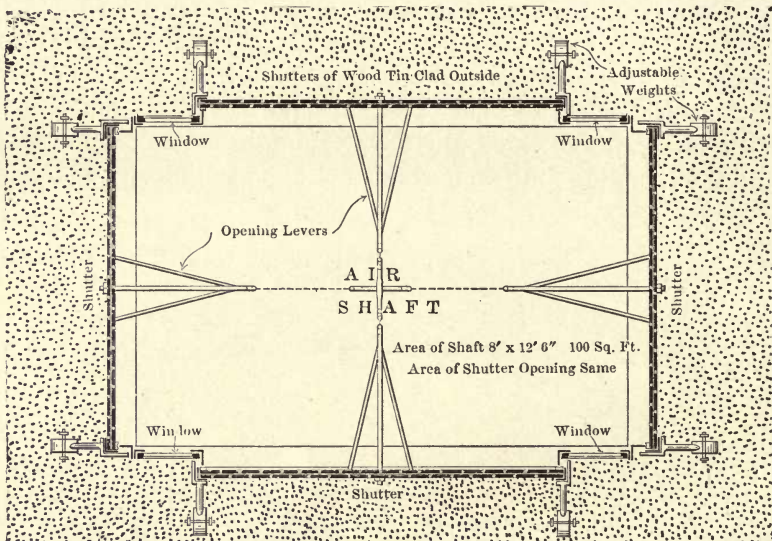

FIG. 5.

5c, 5d, the opening, eight by twelve and one-half feet, of which four would be needed over the stage of ordinary size, has a roof for protection from rain and has vertical sides that contain four small windows for admitting abundant daylight to the rigging loft, but which can be closed by ordinary window shades for dark scenes. All necessity for the wire screen is avoided. The vertical shaft may well be three to five feet taller than shown. The four shutters fall *outward* lest the pressure of the updraft tend to hold them shut, and are pulled open *by force of gravity*, opening to the full area called for. The pull on the rope holds them

against their seat, which, if made with a thin edge pressing loosely against fibrous material, as shown, will be more tight against cold-air drafts than a common window sash or house door. Fusible links are inserted in each of the four branches of the



SMOKE VENT. MONITOR TYPE
HORIZONTAL SECTION

FIG. 5A.

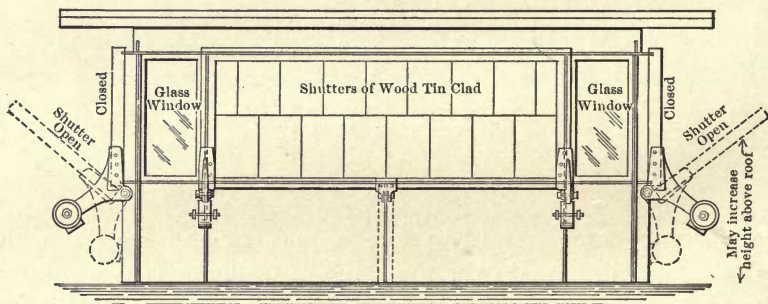

SMOKE VENT. MONITOR TYPE
SIDE ELEVATION

FIG. 5B.

cord. *No sprinkler should be placed up within the monitor containing these links, lest perchance the sprinkler open first and chill the links, and care should be taken that the links are of a thin, quickly sensitive type.*

In the second design, Fig. 6, the sliding type is used. This obviously cannot be used as an ordinary ventilator in rainy days.

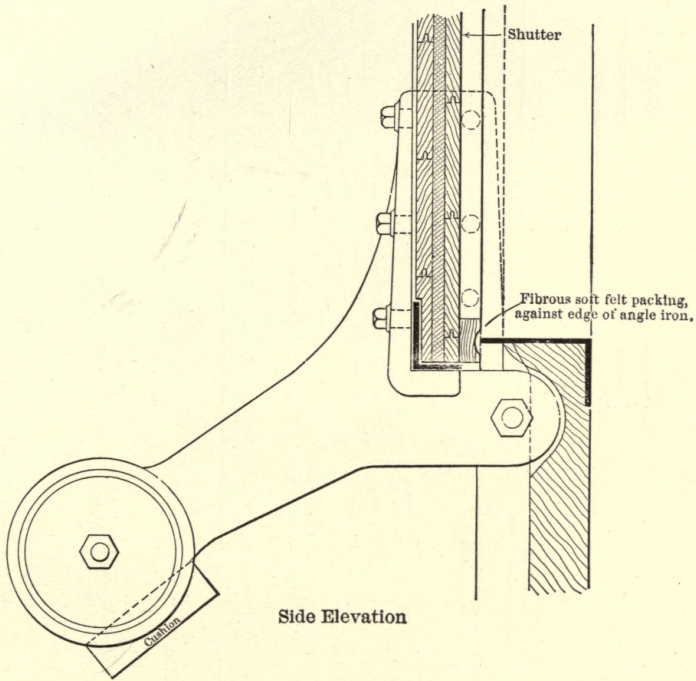

Side Elevation

FIG. 5C.

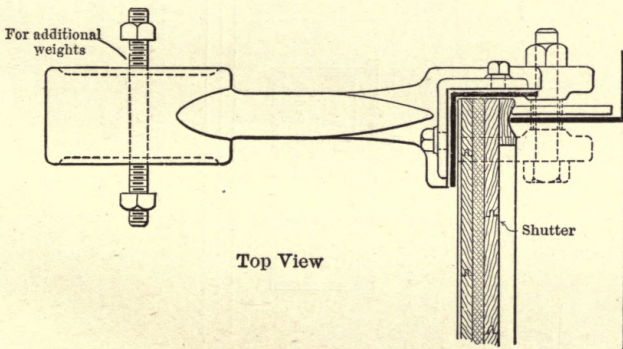

Top View

DETAIL OF WEIGHT
FOR SHUTTER OF SMOKE VENT, MONITOR TYPE

FIG. 5D.

The special effort in remodeling this from the current New York type has been, first, to place the glass in the vertical side so that no necessity remains for a wire screen to catch any broken glass.

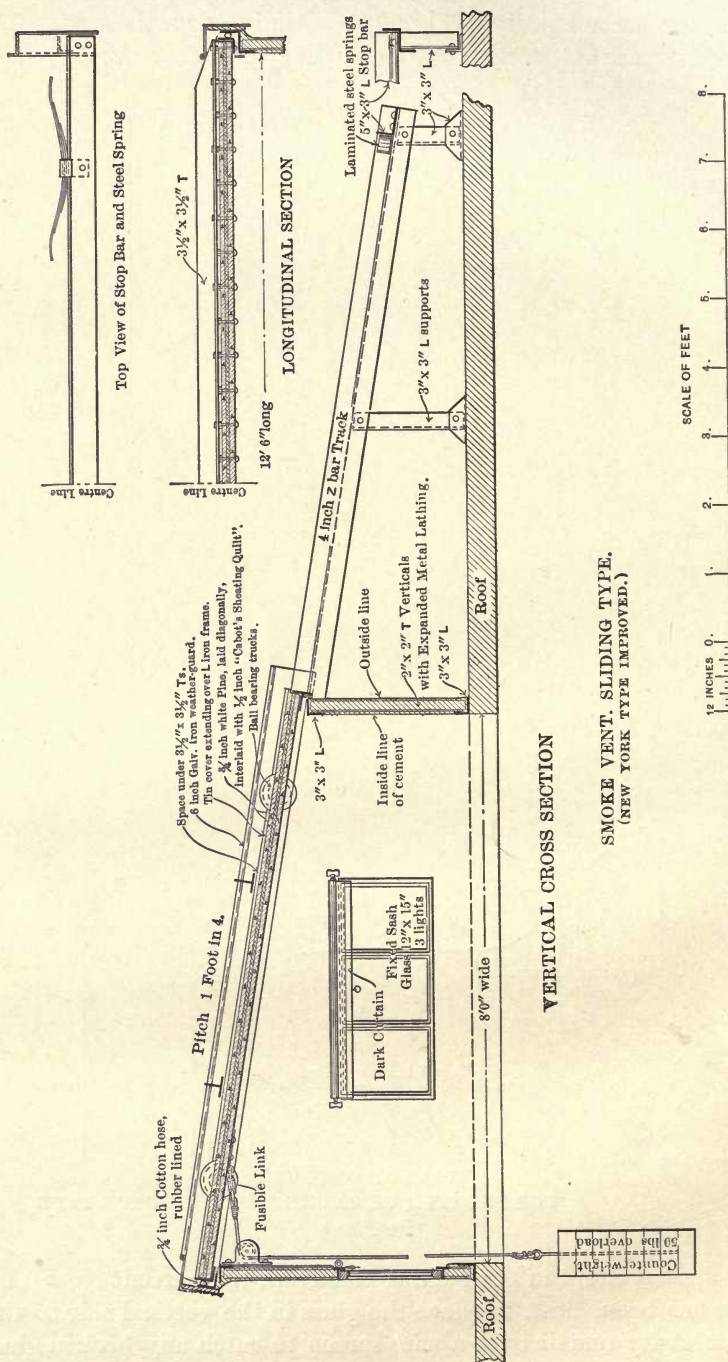

SMOKE VENT, SLIDING TYPE.
(NEW YORK TYPE IMPROVED.)

FIG. 6.

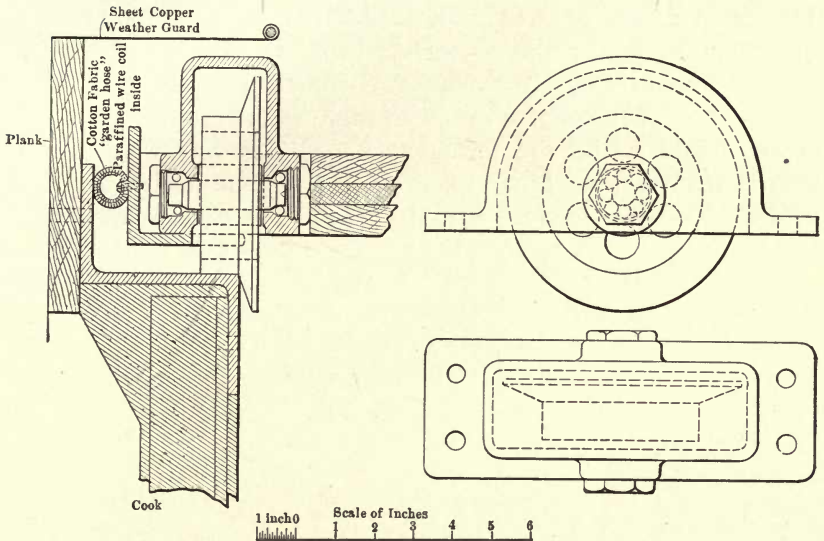

FIG. 6A.—DETAIL AUTOMATIC SMOKE VENT. SLIDING TYPE. DETAILS OF ANTI-FRICTION TRUCK AND OF COLD-AIR STOP.

Second, to provide a better track and trucks and arrange the joints so that the leakage of air through the clearance space would not tempt the janitor to close the space by something that may interfere with the sliding open. Common cotton fabric garden hose, paraffined outside and with an elastic lining or with a thin wire spiral inserted, meets the need for a yielding, non-adhesive packing, if applied as shown.

A third sketch, Fig. 7, shows an arrangement of a safety ventilating shutter that sometimes can be conveniently placed in the brick wall near the top of the rigging loft.

It is dangerous economy to be niggardly about providing the best design and workmanship for the smoke vents, because these are the most important of all the structural safeguards to life in a theater.

AUTOMATIC SPRINKLERS.

The second safeguard in order of importance is, in my opinion, complete equipment with automatic sprinklers over the stage and throughout all rooms and nooks and corners except in the auditorium.

It is now twenty-five years since a former vice-president of this Society, the late Col. Thos. J. Borden, of Fall River, intro-

duced automatic sprinklers in two Fall River cotton mills under his charge, throughout picker rooms, card rooms and spinning rooms. These were put in by Mr. Frederick Grinnell, lately deceased, also a member of this Society, to whom more than to any other man credit should go for the development of this greatest of safeguards against fire. Since that time the factory insurance companies have been slowly led by their wide and varied experience

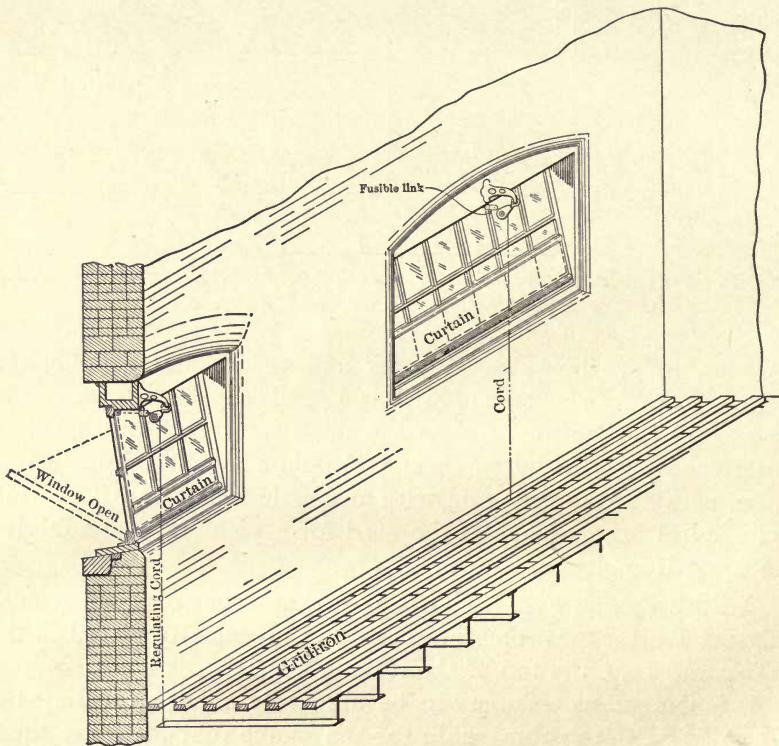

FIG. 7.—AUXILIARY SMOKE VENTS IN WALL ABOVE GRIDIRON.

of 25 years, in thousands of factories, to urge automatic sprinkler protection as the foremost of all safeguards against fire. In the beginning they were recommended cautiously, and only over those portions of factories believed to be the most hazardous. Gradually, as their merits were proved, they were called for throughout wider areas, until it has come to pass that out of about two thousand of the largest factories in America, which entrust their insurance and the supervision of their fire protection to an organ-

zation with which I have long been connected, substantially every ten feet square in mill and storehouse is under automatic-sprinkler protection. We have records of more than a thousand factory fires that have occurred under sprinkler protection, covering a great variety of conditions, and from my own experience in what sprinklers can do to control a fire under adverse circumstances, I unhesitatingly recommend them as the best of all known means for promptly controlling a fire that has once got good hold in the scenery upon the stage of a theater. Like everything else in the mechanical line, they should be skillfully put in.

It has been claimed, as a matter of intuition, by some who have not closely followed the experience with sprinklers over fires, that under the high rigging loft of a theater, sprinklers at a distance of sixty or perhaps eighty feet above the floor of the stage would be so remote from the flames that they would not open with sufficient promptness to be of material service. I am confident that this is untrue. The hot air from a fire quickly travels over a vertical distance of sixty or eighty feet. Not more than five to ten seconds' time would be required for this rise, and the conditions for pocketing and confining the heat to a small area in the top of the rigging loft of a theater are much more favorable than in many portions of factories where sprinklers are found to work successfully.

The rainfall from a series of automatic sprinklers carries ten-fold more water than that from densest ten minutes of the heaviest thunder shower of the ordinary year.

With eighty square feet to the sprinkler and the ordinary water pressure, this sudden artificial rainfall would be at the rate of about twenty-five inches per hour.

One series of sprinkler heads should be placed below the gridiron, and preferably another series above it, these not being vertically over one another. Those in the top series are as likely to open first, but it is well to be liberal and provide both series. A line should also run along the lower outer edge of each fly gallery. With care, a skillful sprinkler fitter can readily place and guard all the heads and pipes so the danger of breakage need be no greater than in a factory. The one hundred and sixty-two-degree solder should be used and the piping should be on the "wet system."*

* The foundation patents on these devices have expired. Half a dozen different good makes are on the market. Under the somewhat difficult conditions of

Stage scenery, while exposed to very rapid ignition, is equally well exposed to very rapid drenching, and the fact that we have so few actual records of what sprinklers can do in controlling a fire on the stage is due to the few instances where sprinklers have been installed in theaters, or have had an opportunity to demonstrate the work of which they are capable. At least there have been no failures, and there are several most notable successes to their credit. The first was in a case where they had been put into a theater because Mr. Cumnock, a factory manager who was one of the stockholders, had been satisfied of their efficiency by fires that they had extinguished in his cotton mill.

This was at a theater in Woonsocket, R. I., in which a gauze piece took fire from the border lights prior to the performance, and sprinklers opened under the gridiron sixty-five feet above the floor, while other sprinklers opened under the roof eighty feet from the floor.* At theaters in Philadelphia, in New York City and in Providence, R. I., there have been notable instances of fires when the audience was absent, from spontaneous combustion and overturned lamps, in which the sprinkler extinguished the flames, and from Manchester, England, a case is reported of a fire in a "gauze sky," between the acts, extinguished by four

installing them about a theater the cost for sprinklers, pipes, fittings and erection will average, perhaps, \$5.00 per head. In factories the cost averages about \$3.00 per head.

The heads are placed from 8 to 10 feet apart, and fed from the public water supply or from elevated tanks. The cost of tanks and main water supply is not included in the estimate above, and is liable to bring the total cost to \$10.00 per head in theaters, varying widely according to circumstances. In cities with low pressure a large tank for water supply adds materially to the expense.

With a stage of medium size, say 40 x 60, or 2,400 square feet and 80 square feet per sprinkler, 30 heads would be required on the ceiling above the gridiron, and 30 more just below the gridiron. About 10 heads more would be needed in lines along the edge of fly galleries, and perhaps 30 more beneath the stage, making, say, 100 sprinkler heads for the stage portion of a medium-sized theater.

The dressing-rooms, auditorium, basement, carpenter's room and various odd corners are likely to call for another hundred sprinklers, so that 200 sprinklers would perhaps be an average equipment.

Some very large theaters have taken 500 sprinkler heads.

The saving in cost of insurance commonly goes far toward paying good interest on this cost, leaving the safeguarding of life as costing little or nothing.

* This case was so complete an answer to the suggestion that sprinklers at the top of a high stage are too far off to work with promptness, that I sent an engineer to measure the distances and sketch the surroundings. These sprinklers worked so effectually that the wooden gridiron was not burned. The sprinklers appear to have put out this fire after it got away from the man with the stage hose.

sprinklers thirty feet above the flies so promptly that although the stage and scenery were wet, the performance went on without the audience knowing just what had been going on while the curtain was down.*

The reasonable safety of the public requires that automatic sprinklers be persistently urged, followed up and demanded under

* Abbreviated from *The Standard*, Boston, February 3, 1906.—At the Colonial Theater, Jan. 20th, the house held a large Saturday matinee audience. Near the close of the performance a strong odor of burning wood was noticed. The automatic alarm and sprinkler signals worked perfectly, and when the firemen arrived it was found that a sprinkler head *had completely extinguished the fire*, which had caught in a box of properties located under the stage. "It should be required by law that all places of amusement be thoroughly equipped with sprinklers and alarms. There are several theaters in Boston not so equipped."

From report of Committee on Surveys, N. Y. Board of Fire Underwriters.—Nov. 29, 1905, Grand Opera House, New York City. About 7 A.M. *fire originated in a quantity of scenery* at side of stage. Cause unknown. Thirty-six automatic sprinklers opened and held fire in check. The sprinkler alarm called watchmen, who summoned Fire Department, which completed extinguishment. That 36 sprinklers were unsoldered proves a lively blaze. (That fire could originate in a lot of scenery is interesting in view of the fact that law requiring flame-proofing of all scenery is understood to be now enforced in New York City.)

At the Kensington Theater, Philadelphia, July 30, 1895: Fire occurred at night, probably from spontaneous combustion in a newly painted drop curtain, done in oil colors, and communicated to a side-piece that stood against the proscenium wall. A single automatic sprinkler opened and thoroughly drowned out the fire, which the owner, Mr. John W. Hart, believes would otherwise have quickly spread and wrecked his theater. He writes enthusiastically recommending automatic sprinkler protection for all theaters.

At the Providence Opera House on Sunday morning, September 23, 1900: Combustion started in some garments left on a small trap below the stage—perhaps from a cigarette after the performance of the previous evening. One sprinkler head located about eight feet above opened and the sprinkler alarm summoned the protective department, who found the fire practically extinguished by the water from the sprinkler.

At the Casino Theater, New York, January 11, 1900, about 8.15 P.M.: Fire was started by the upsetting of a lamp in a dressing-room filled with flimsy material. Two automatic sprinklers opened and, it is said, practically extinguished the fire, although the stage fire hose was also brought into service.

At the Queen's Theater, Manchester, England, on July 20, 1899: "As gas was being lighted in the wings, a gauze sky caught fire and ignited several curtains or cloth hangings near it. Soon there was a big blaze, but four sprinklers situated about 30 feet above the flies opened, almost immediately, and before the fire brigade arrived the fire was out."

At White's Opera House, McKeesport, Pa., December 6, 1903: A letter from the proprietor states—We had a slight fire in the basement yesterday and about eighteen sprinklers opened. Thanks to the sprinkler equipment the damage to the building will not exceed \$50.00.

At Keith's Chestnut Street Theater, Philadelphia: It is reported that a fire

the building laws and police laws until every theater using movable canvas scenery has this protection over its stage. There are half a dozen well-proved makes, and plenty of experienced sprinkler fitters can be found to properly erect them.

Possibility of Leakage of Automatic Sprinklers.

A leading argument against automatic sprinklers has been the possibility that they would break open when there was no fire, and thus injure the scenery. We have statistics to show how extremely small this danger really is.

Our records, when I last had them compiled, showed that out of a total of something over three million sprinkler heads scattered through more than two thousand different factories, losses from premature discharge were occurring at the rate of about fifty sprinkler heads breaking open per year. This proportion of one sprinkler in each sixty thousand springing a leak per year, when applied to the conditions in a theater that would commonly have less than one hundred and fifty sprinkler heads over the stage, although they were put in both under and over the gridiron and under the fly galleries, would give a probability at any one particular theater of a leak over the stage once in four hundred years.* Should we admit, which is not certain, that the danger of knocking one of these sprinklers open by a blow is greater in the theater than in the factory with its moving machinery, and assume even that they break tenfold more often, it is plain that this danger of leakage is no just ground for excluding sprinklers from over a theater stage.

Our insurance companies do not hesitate to recommend them

occurred in one of the dressing-rooms, presumably by fabrics coming in contact with gas jet, although this jet was protected by a globe. The sprinkler extinguished the fire without outside assistance, and, in fact, on the arrival of the employees no fire existed, but some dresses were burned and the cleats to which they had hung were charred.

* Later, in going over the replies to my circular of inquiry sent to managers of all known sprinklered theaters in United States and Canada, I find that cases of the accidental bursting open of sprinkler heads have occurred in far greater frequency than is found in factories. Perhaps half of the theaters reporting have had one or more such accidents, due, in nearly all cases, to allowing the temperature to fall so low that one or two sprinkler heads have frozen and burst. In no case does it appear that any serious damage was caused. Obviously, these accidents should be charged to carelessness and not to defects in the sprinkler head; and, obviously, an accident of this kind will seldom be allowed to happen more than once in the same theater.

for a packing and storage room over a quarter million dollars' worth of delicate silks or finest textiles, and so little do we fear the premature discharge that in the fire insurance we guarantee against this water damage in our fire policies with no additional charge. Our careful records show that we are paying for water damage by the premature discharge of sprinklers and the bursting of their pipes and fittings from frost, blows, carelessness and inherent defects, about 5 cents per year per thousand dollars of value covered!

The idea that the fine spray or rain of water from a single opened sprinkler head falling vertically and probably invisible to most of the audience could produce a panic within the audience, however much it might disturb the chorus, is too absurd for serious argument.

Sprinklers, although not so generally used over the stage as they ought to be, have been introduced here and there, and in some cities quite generally. The great theater at Bayreuth, Bavaria, the home of the Wagnerian opera, was completely fitted up with automatic sprinklers eight years ago, 666 sprinkler heads being installed. I now have the record of about one hundred and fifty theaters that have been sprinklered. I sent a circular letter to the managers of many of these theaters asking for their experience. In no case did I receive an adverse criticism, and in the majority of cases they speak in most appreciative terms of the value of this safeguard.

FIRE CURTAIN.

The third of the safeguards demanding investigation is the curtain for closing the proscenium arch.

With good smoke vents and complete automatic sprinkler protection over the stage, and with ample stairways from galleries, it is probable that the audience could escape from a situation as bad as that in the Iroquois, notwithstanding there was a very poor fire curtain, or perhaps no curtain at all; but in theaters, as in factories, it is wise to have a second and even a third line of defence, lest the first happen to be inoperative in the moment of need.

The fire curtain for covering the opening under the proscenium arch in nearly all American theaters outside Chicago, at the present time, is made from a heavy canvas woven from asbestos fiber; and in English theaters the asbestos curtain appears to

have been steadily gaining in favor because of its less weight and smaller cost in comparison with a curtain of sheet iron, stiffened by iron ribs. In Chicago, because the failure of the Iroquois asbestos curtain, and with the excellent corrugated iron curtain of the Auditorium before them, the Aldermanic Committee has made the steel curtain the rule. Chicago to-day leads the country in the substantial quality of its proscenium curtains, and in the present state of the art they merit little criticism except in their lack of a positive down-haul and their need of better holding and guiding in iron channels at the edge.

Like nearly all steel-ribbed shutters, these steel curtains will warp and twist off their seats under ten to fifteen minutes of exposure to a severe fire unless securely held at edges, and should smoke vents be closed and sprinklers lacking and a back door open, their loose fit would let volumes of suffocating smoke and tongues of flame pass by their edges into the auditorium. With the smoke vents open and the draft therefore inward, they will serve their purpose until the audience has escaped and the firemen have arrived.

Special attention was directed to the asbestos curtain in the Iroquois fire from the fact that the curtain, *although promptly let loose, failed to fall*; because, as some say, it was blown outward from the stage by the strong current of air; or because, as others say, it caught on certain of the electric light shields.

It is a fact that the asbestos canvas soon fell as mere rubbish to the stage, but so little that resembled a piece of asbestos canvas could be found in the wreckage on the stage that it was for some time believed that the curtain had not been made of asbestos.

It is now certain beyond question that this Iroquois curtain actually was made of a good, ordinary commercial quality of asbestos canvas, but somewhat thinner than the very best, and it is doubtless true that this Iroquois curtain was just as good as those which hang to-day in the great majority of our theaters. I personally found fragments of this asbestos cloth in my first examination of the stage while everything was just as the fire left it, and later I secured samples which, although brittle, "rotten," or without cohesion of fiber, are in all respects similar to what I obtained by exposing a sheet of new, thoroughly first-class asbestos cloth to a moderate flame temperature for the space of five minutes.

The asbestos curtain at the Iroquois theater was an utter failure in three different ways :

1st, as already stated, it could not be lowered, and stuck fast after descending a distance variously estimated at from

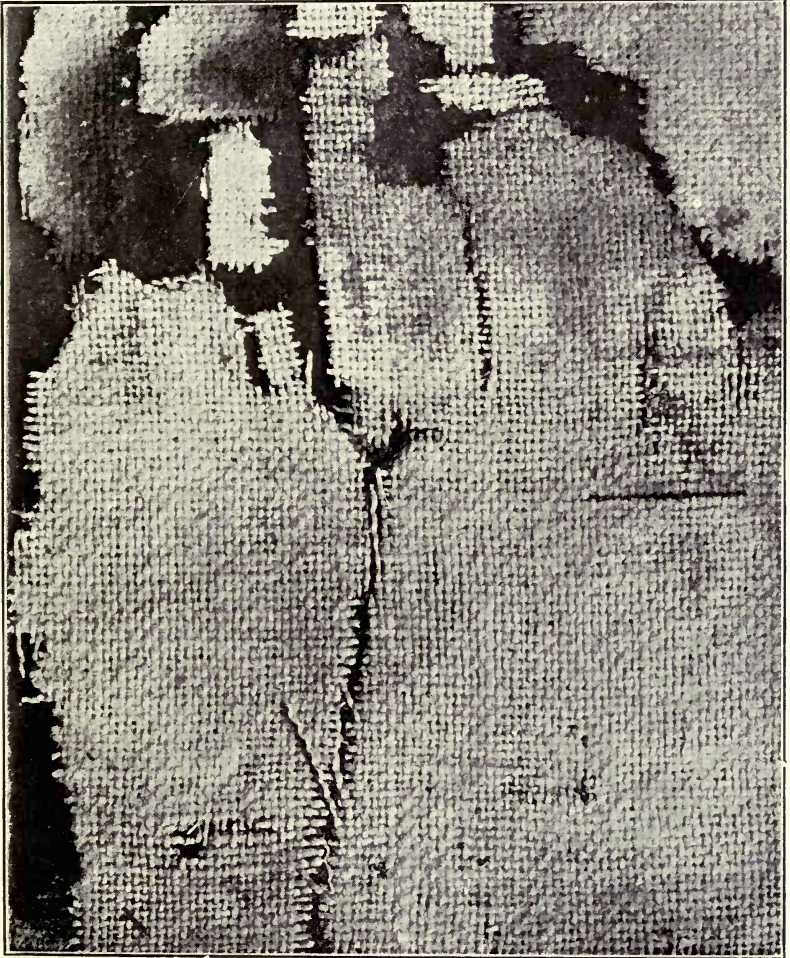

FIG. 8.—A SAMPLE OF THE IROQUOIS CURTAIN TAKEN FROM THE STAGE AFTER THE FIRE.
(From a photo.)

one-fourth to one-half the height of the proscenium arch.

2d, the Iroquois curtain was improperly hung, being supported at the top in part by being clamped between thin strips of pine wood about four inches in width by three-fourths of an inch in thickness. (So tolerant is the

public and so easy are public building inspectors, that I have myself seen in actual use in several theaters examples of an asbestos curtain hung from a batten of white pine to which it was nailed across the top.)

3d, the asbestos canvas of the Iroquois curtain, when exposed to actual fire, lost its strength and fibrous quality almost completely, and became so brittle that it would crumble under a very slight pressure, and became utterly incapable of withstanding the pressure of a strong draft of air, and too weak to hang up under its own weight.

CONCERNING ASBESTOS.

The word "asbestos" has become, in the public mind, a synonym for perfection in fire-proof material, but the investigations now to be described have made me believe that a simple asbestos curtain of even the very best quality will not form a durable and certain fire screen for the proscenium arch when exposed to a bad fire.

Any asbestos curtain may be expected to resist the ridiculously inadequate test of the flame of a gasoline torch, and any well hung asbestos curtain, *if it can be pulled down*, will probably endure longer than the brief period of two or three or four minutes, within which it should be possible to empty any theater; and meanwhile it might serve a most useful purpose in screening the flames from direct view.

In opposition to the failure of the Iroquois asbestos curtain we have an interesting test of action of asbestos curtain and smoke vents combined in the fire that destroyed the Girard Avenue Theatre in Philadelphia, on October 28, 1904, and which broke three hours after midnight on the stage when no one was present. On the arrival of the public fire department, three minutes after the first alarm, the flames were coming out of the skylight ventilators over the stage, which it is said were of one-eighth the stage area, and had opened automatically. The firemen at first found no fire or smoke in the auditorium, and the curtain hung there, and probably with the aid of the cool indraft toward the stage, kept flames out of auditorium for a period said to be fifteen minutes. Shortly after this the fire somehow passed into the auditorium; doubtless around the edge of the curtain or by the curtain becoming ruptured by falling material. It is curious to

observe how this case has been quoted as a triumph for the asbestos curtain, while the more important part played by the smoke vents was completely lost sight of!

While I regard this record as more of a triumph for the smoke vent than for the curtain, it is of great interest to note that under existing conditions, whatever they were as to quantity of burning scenery, this curtain, with the open smoke vents of one-eighth the area of the stage, lasted much more than long enough to have covered the escape of an audience. In all probability, this fire was much less fierce and rapid than the Iroquois and had far less scenery on the stage.

In the United States asbestos canvas costs anywhere from \$1.25 to \$3.50 per square yard, according to weight and texture, and a proscenium curtain of asbestos may cost anywhere from say \$175 to \$600.

In order to learn what difference there might be between different makes and grades of asbestos canvas, I obtained through various channels samples, each one or two yards square, from all of the prominent American manufacturers of theater curtains and also from each of the American manufacturers of asbestos cloth. I also cabled to London and had an architect familiar with theatrical work collect samples of asbestos curtain cloth none less than a yard square from the leading English manufacturers and dealers, under instructions to use every effort to procure some canvas that was woven from French or Italian or other than Canadian fiber.

When pressed hard for the pedigree of their samples, no one of these makers would furnish asbestos canvas under a guarantee that it was made from anything other than the Canadian fiber, and on chemical analysis, all of our specimens of canvas, obtained either at home or abroad, were found to be of a chemical constitution similar to that of the Canadian fiber.

The Canadian mineral is not the kind to which the name asbestos was first applied and, strictly speaking, is not true asbestos.

The Canadian asbestos is a fibrous crystalline variety of serpentine and contains about thirteen per cent. of water in chemical combination, plus a little hygroscopic water; whereas the form to which the name asbestos was first applied by the ancients contained no combined water whatever.

There are two or three minerals of very different chemical constitution which go under the name of asbestos:

1. Chrysotile, which contains about fifteen per cent. of water, twelve and nine-tenths per cent. chemically combined, and about two per cent. hygroscopic. This is essentially a silicate of magnesia.

2. Tremolite, which is anhydrous and is a silicate of lime and magnesia, with sometimes a little iron.

3. There is a mineral which is asbestiform in character, a silicate of iron and magnesia, known as anthophyllite.

The first named loses its strength at about six hundred and sixty degrees Centigrade, or just below redness, on the driving off of its water, but the last two, containing no combined water, stand more heat and are said not to fuse until about thirteen hundred degrees Centigrade, equal to twenty-four hundred degrees Fahrenheit, is reached. We did not measure this high fusing point. The behavior of some filaments in a blast lamp indicates a lower fusing point for the tremolite asbestos than as just stated on text-book authority.

The Canadian fiber is Chrysotile. This is now the common asbestos of commerce, and possessing in greater degree than the others the properties required for spinning and weaving, has come to be the only kind used in the manufacture of asbestos canvas.

The Georgia asbestos, although free from water in its chemical combination, and therefore not decomposing at low red heat, has for the most part a fiber too brittle for spinning, and is used for purposes not requiring strength of fiber.

The anhydrous Tremolite and amphibole asbestos are also found in Siberia and in South Africa; but all the anhydrous asbestos mined or quarried makes up an insignificant part of the asbestos of commerce, and although some of the cabinet specimens of anhydrous asbestos have long, silky, pliable fiber, I was unable to anywhere obtain cloth made from anhydrous asbestos.

Several kinds of asbestos canvas can be procured in the market. There is a distinction sometimes made in the trade between "absolutely pure" asbestos canvas, which contains no cotton, being made for filter cloth or other industrial purposes, and "commercially pure" asbestos canvas, which may contain from five per cent. to fifteen per cent. of cotton carded in with the asbestos fiber. These can be distinguished by picking a piece of the yarn into fine feathery condition and touching a match to the ends of the fiber and noting the flash and smell of burned cotton.



Certain manufacturers claim that a small percentage of cotton, besides facilitating the spinning and weaving into a strong, pliable canvas, improves the cloth for the purpose of painting a picture upon it, as for a drop curtain, and claim that this small amount of cotton does not impair its fire resistance. Asbestos fibers are very slippery and difficult to card and spin, and by taking advantage of the spiral structure of the relatively few cotton fibers to bind the asbestos fibers together, the process of manufacturing a smooth canvas is greatly facilitated.

A third variety of asbestos cloth which has been highly recommended (on *a priori* grounds rather than from tests), by fire chiefs and architects for a theater curtain, contains very fine brass wires, of No. 33 and No. 34, standard gauge, or only about the $\frac{1}{150}$ part of an inch in diameter, woven in with the asbestos yarn. My tests proved that *these fine wires add nothing to the strength of the heated canvas*. The wire used was found by analysis two-thirds copper, one-third zinc, with a trace of lead, perhaps two per cent.; this analysis proving it to be an ordinary brass wire. Probably the extreme fineness of the wire used and the quick oxidation or volatilization of the zinc is a cause of its weakness when heated.

All of the alleged asbestos curtains that I have seen have really been of the ordinary commercial asbestos, and I regard the stories of painted burlap masquerading as asbestos in theater curtains as mostly idle talk.

Test of Asbestos Canvas.

Since my experiments on the effect of heat upon the tensile strength of asbestos cloth and asbestos fiber quickly disclosed that the ordinary commercial asbestos lost its strength at a heat just below redness, sufficient to drive off the combined water, in order to be sure of our ground, I had three independent series of tests upon asbestos made by three different experts, and by very different methods, myself laying out only the outlines of the test desired and leaving the observations and reports to the respective experts. The results of all three tests proved independently that the character of asbestos cloth as to resisting a high degree of heat is utterly different from what is popularly supposed.

1st Series.

The first series of tests were made by Prof. Charles E. Fuller, in the Mechanical Engineering Laboratory of the Massa-

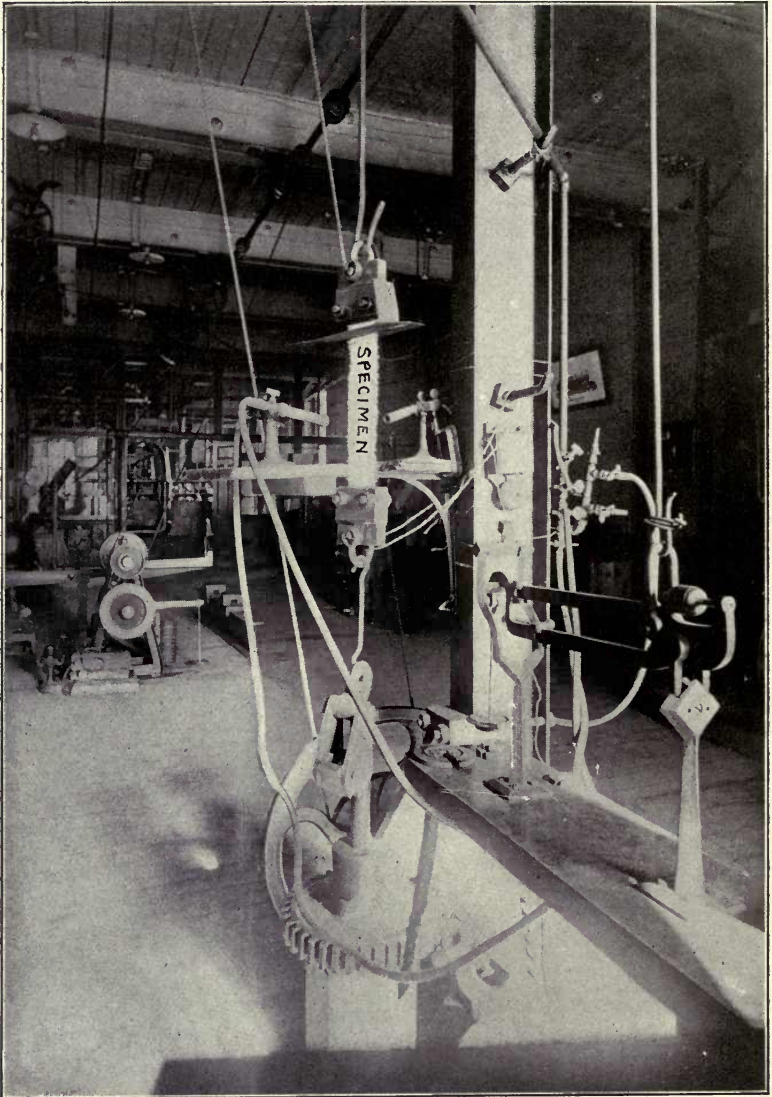

FIG. 9.—ARRANGEMENT FOR TESTS OF STRENGTH OF ASBESTOS CANVAS IN MECHANICAL ENGINEERING LABORATORY, MASSACHUSETTS INSTITUTE OF TECHNOLOGY. TENSILE STRENGTH MEASURED EITHER COLD OR WHILE HEATED BY COMMON GAS FLAME OR BY BLAST LAMP FLAME TO VARIOUS DEGREES.

chusetts Institute of Technology, on a special testing machine designed for measuring the strength of sailcloth, and which had been previously used in a series of tests for the United States Government. We had this newly fitted with double Bunsen gas burners, as shown in Fig. 8, so arranged that a specimen could be either tested cold or tested for strength while heated to any desirable degree in either an ordinary gas flame or heated up to moderate redness in the flame of the blast lamps. These tests were made with great care, repeating the test on two or more specimens in almost every case and with a degree of attention to detail which I have not space here to set forth. I believe the results absolutely reliable.

In brief, *we found that every one of these specimens of asbestos canvas, English, French and American alike, when heated for from two to five minutes to a little below redness in a common gas flame, or barely to redness in the Bunsen flame, lost from sixty per cent. to ninety per cent. of its strength, and that the fiber became very brittle.*

We were surprised to find that the samples with the wire insertion, when tested hot, were no stronger than the samples without wire. On cooling, they regained a little of the strength due to the wire.

I have condensed the results of these tests into the tables which follow on pages 110-113.

At time of weighing and measuring thickness of American samples, relative humidity of air was 80 per cent., temperature, 68 degrees F. When weighing and measuring foreign samples, relative humidity, 25 per cent., temperature, 71 degrees F. Thickness measured between glass plates, 2 inches square, under 8 lbs. pressure. Specimens prepared by cutting strips $2\frac{1}{2}$ inches wide and ravelling out threads carefully from edge until width of 2 inches to the nearest thread was left.

All specimens held with 12 inches between the grips.

Load applied, in nearly all tests, by stretching the cloth at rate of $\frac{1}{2}$ inch per minute. A few tests were run at speed of stretching at rate of $\frac{1}{4}$ inch per minute for comparison, and no difference found in strength between these rates of speed.

The results of test of strength while hot, given in the table, are averages from three specimens. These three different trials gave substantially uniform results.

TABLE I.—EFFECT OF HEAT UPON STRENGTH OF ASBESTOS CANVAS (FOREIGN SAMPLES).

Letter marked on sample.....	Plain cloth without wire.					With fine wire spun in yarn and woven in.				
	B	C	D	F	G	A	E	G	H	
Name of manufacturer.....	Germain Boisne, Freres et Cie, France.	Germain Boisne, Freres et Cie, France.	Germain Boisne, Freres et Cie, France.	Leyland & Birmingham Rubber Co., England.	Leyland & Birmingham Rubber Co., England.	United As- bestos Co., Ltd., Eng- land.	Merry- weather & Co., Eng- land.	Leyland & Birmingham Rubber Co., England.	Bell's As- bestos Co., Ltd., Eng- land.	
Equiv. selling price (in London) per sq. yd. not made up into curtain*.....	\$1.50	\$0.45	\$0.55	\$0.37	\$0.60	\$1.25	\$0.90	
Actual weight of cloth per sq. yd. in lbs.....	3.00	1.80	1.71	1.98	3.00	2.52	2.88	3.00	2.43	
Average thickness in inches (between glass @ 2 lbs. per sq. in.).....	.072	.044	.068	.058	.079	.069	0.	.079	.059	
Statement of per cent. of cotton contained.....	0.	3.	38.2	16.5	0.	
Per cent. loss of weight found after heating bright red (mean of 2 samples).....	13.6	17.6	30.1	11.9	17.4	
Probable actual per cent. of cotton.....	0.	1.6	14.	2.5	6	7.	0	3.4	
No. of warp threads per inch.....	27.	41.	27.	30.	36.	35.	27.	41.	
" " strands in asbestos yarn.....	2.	2.	2.	2.	1.	1.	1.	2.	
" " brass wires in each.....	0.	0.	0.	0.	1.	1.	1.	2.	
Warp: Diameter of wire in inches.....0076	.0062	.0062	.0061	
Breaking load 1 wire, cold in lbs. (mean of 3).....	3.12	1.97	2.32	1.88	
Total strength of wire per inch in width in lbs.....	56.	34.5	29.8	37.6	
Filling: No. of filling threads per inch.....	32.	35.	32.	27.	19.	19.	22.	26.	
" " strands asbestos yarn.....	2.	1.	2.	2.	1.	1.	1.	1.	
" " brass wire.....	0.	0.	0.	0.	1.	1.	1.	1.	
Diameter of brass wire in inches.....0064	.0061	.0062	.0061	
Breaking load 1 wire cold in lbs.....	2.30	1.90	2.10	1.90	
Total strength of wire per inch in width in lbs.....	22.	18.	23.	24.5	
Stretch of Cloth at Maximum Load: Per cent. of elongation lengthwise (mean of 2).....	15.6	15.3	13.9	13.0	14.	14.5	16.1	12.5	
" " " " crosswise.....	8.1	10.3	6.8	6.0	4.6	6.2	10.9	6.3	
Strength of Cloth Tested Cold (in lbs. per inch in width). Crosswise—Filling.....	119.	56	50.	20.	49.	42.	53.	53.	
Lengthwise—Warp (mean of 2).....	130.	112.5	49.	81.	72.5	97.5	113.5	128.	
Strength of Cloth While Heated (in lbs. per inch in width). All of following samples tested lengthwise (warp). Heated 1 side with a "blast lamp 1 min. Dual red—broken while hot.....	31.5	16.5	7.7	22.3	3.	11.2	18.8	16.	
Heated 1 side with a "blast lamp 5 min. Dual red—broken while hot.....	17.5	14.1	8.8	13.9	4.0	9.0	12.4	16.3	
Heated both sides with blast lamps 5 min. Bright red—broken while hot.....	18.4	14.8	7.0	14.8	2.3	9.9	11.5	9.7	
Heated 1 side in common gas flame 5 min. Broken while hot.....	60.2	34.5	9.0	36.8	11.2	21.2	36.5	32.	
Heated 1 side in common gas flame 5 min. Broken while hot.....	44.0	18.5	8.3	25.0	8.5	14.0	30.2	24.	

The following tests were made on strength of samples of asbestos twine, cord, and rope, manufactured by the H. W. Johns-Manville Co.:

TABLE 3.

Material.	Description.	No. of Specimen.	Breaking Load.	ELONGATION AT MAXIMUM LOAD.				
				Measured Length.	Elongation.			
Three-eighth-rope.	3 strands, each made up of 8 threads of plain asbestos with a manila core. Each thread made up of 2 strands of yarn, of which 15.5 ft. in length weighed 1 pound.	11-1	588 lbs.	broken cold.	3 inches.	18.7%		
		11-2	600 lbs.	broken cold.				
		11-3	108 lbs.	{ broken hot after heating dull red 5 minutes.				
		11-4	81 lbs.	{ broken hot after heating bright red 5 minutes.				
One-quarter-inch rope.	3 strands, each strand made up of 4 threads of plain asbestos. Each thread made up of 2 strands of yarn, 67.5 feet per pound.	12-1	330 lbs.	broken cold.	3 inches.	14.6%		
		12-2	45 lbs.	{ broken hot after heating to dull red 5 minutes.				
		12-3	37 lbs.	{ broken hot after heating to bright red for 5 minutes.				
One-eighth-inch cord, No. 804.	4 threads of plain asbestos, each thread consisting of 2 strands of yarn, of which 130.5 feet weighed 1 pound.	13-1	143 lbs.	broken cold.	12 inches.	7.3%		
		13-2	132 lbs.	broken cold.				
		13-3	124 lbs.	broken cold.				
		13-4	14 lbs.	{ broken hot after heating to dull red 5 minutes.				
		13-5	18 lbs.	{ broken hot after heating to bright red for 5 minutes.				
		13-6	35 lbs.	{ broken hot after heating in common gas flame 5 minutes.				
Plain asbestos sewing twine.	2 strands plain asbestos yarn, of which 1,364 feet weighed 1 pound.	14-1	12.8 lbs.	broken cold.				
		14-2	11.3 lbs.	broken cold.				
		14-3	1.0 lbs.	broken cold.				
		14-4	1.1 lbs.	{ broken hot after heating bright red 2 minutes.				
		14-5	1.0 lb.	{ broken hot after heating bright red 5 minutes.				
		14-6	0.8 lb.	{ broken hot after heating in common gas flame 5 minutes.				
Sewing twine with wire insertion.	2 strands of plain asbestos yarn, 2 strands of brass wire; diam. .0070 inch; 833.3 feet per pound. Breaking strength of 1 wire cold, 2.12 pounds.	15-1	17.0 lbs.	broken cold.				
		15-2	19.5 lbs.	broken cold.				
		15-3	16.5 lbs.	broken cold.				
		15-4	2.1 lbs.	{ broken hot after heating bright red 2 minutes.				
		15-5	1.9 lbs.	{ broken hot after heating bright red 5 minutes.				
		15-6	2.3 lbs.	{ broken hot after heating in common gas flame 5 minutes.				

It will be seen from the above that the asbestos cord was affected by heat very much as the canvas was, and lost nearly all of its strength after brief exposure to dull red heat, or even to a heat a little below.

2d Series.

I desired tests on larger sheets of the canvas, more nearly reproducing the conditions of use, and so the tests of our second series were made at the Underwriters' laboratory, in Chicago, by constructing asbestos curtains about six feet square and testing them with the same furnace and apparatus that had been provided in the yard attached to this laboratory for testing fire shutters and fire doors. Unfortunately, we found the furnace in poor working condition because of a temporary defect in the gas supply, such that we could not regulate the temperature evenly over the entire curtain or measure it precisely by the pyrometer. After testing several curtains we therefore suspended these tests.

The large sheets under these conditions made a much better showing than the small samples had made in the laboratory. Nevertheless these Chicago tests fully confirmed the conclusion, derived from our Boston tests, that asbestos cloth is rapidly weakened by the heat of an ordinary fire to an extent that makes a curtain composed wholly of asbestos cloth an unreliable fire screen for the proscenium arch of a theater, if expected to endure more than a few minutes; and it was proved that the asbestos canvas was so weakened that it would be ruptured easily by a blow from any falling material or by a strong current of air. It was noted during these tests that the Johns curtains were found particularly weak in their horizontal threads, permitting vertical rents to be easily made. That the canvas of the other makers is similarly much less strong horizontally than it is vertically, or in the warp threads, may be seen from the Boston tests set forth in the previous table. The seams sewed with asbestos thread showed no special weakness more than the canvas.

A notable feature in these furnace tests with those curtains that contained from five per cent. to eight per cent. of cotton was the flame that played all over the outer face of the cloth when the furnace was lighted, and which might be disquieting to an audience in giving for a moment an impression that the asbestos curtain was burning up.

3d Series.

For the third series of tests, the friendly services of Prof. William Otis Crosby, of the Massachusetts Institute of Technology, in charge of the Department of Economic Geology, and Dr. C. H. Warren, Professor of Mineralogy in the same institution, were

enlisted to examine all of the varieties of asbestiform mineral found in the extensive cabinets of the Institute of Technology and the Boston Society of Natural History, in the hope of finding specimens from some locality that possessed all the qualities properly attributed to asbestos. The result of this search, in brief, was that nothing was found possessing characteristics materially different from the hydrous Canadian fiber on the one hand, and the anhydrous fiber from Georgia on the other. Specimens of asbestos of the first class lost their strength at a heat which drove the water off; the specimens of the second class had fibers that were too stiff or too brittle for spinning and weaving, or they were reported as occurring in quantity too small for commercial purposes.

Tests were next made by Professor Warren to learn the precise degree of heat required to injure the strength of asbestos fiber.

Upon testing specimens of the Canadian fiber by heating it in a platinum crucible within a clay cup and within a coil heated electrically, raising the temperature slowly, weighing the specimen repeatedly, and all the time measuring the temperature in the crucible by electrical methods, it was found that a temperature up to 250° Centigrade, equivalent to 482° Fahrenheit, caused no driving off of the water chemically combined, and no apparent change in the pliability or strength of the fiber.

A heat just below dull redness proved to be the critical point. One-half hour at from 440° C. to 480° C., equivalent to 850° F., drove off about three per cent. of the combined water and made the fiber slightly more brittle than at first, with some loss of natural luster.

Heated to from 630° to 650° C. for five minutes, averaging 1,152° F., eleven per cent. of the water is driven off, and the fiber becomes slightly brown and very brittle and crumbly.

Heated for only thirty seconds to 750° C., the fibers of Canadian asbestos lost their cohesion.

A faint red heat corresponds to about 1,100° F. (The Austrian engineers, from their experiments on a theater model in 1885 already referred to, concluded that a temperature of 800° C., equal to 1,472° F., would be reached in a fire on a stage crowded with scenery.)

In other trials Professor Watson found that a piece of asbestos canvas a foot square lost its strength badly, so that it could be torn between the fingers, after it had been held five minutes

against a moderate wood fire that did not heat it to visible redness, and therefore probably not to 650° C.

From a series of such tests Professor Warren concluded that a theater curtain made of the Canadian or chrysotile asbestos fiber alone could not be expected to hold together for more than a few moments if a temperature of 650° C., equivalent to about $1,200^{\circ}$ F., was reached, and calls attention to the fact that, being a non-conductor, the asbestos canvas would arrest and absorb the radiant heat from the burning scenery and have its own temperature rapidly raised.

In the course of sundry other tests he found independently that the fine brass wire inserted in certain samples of the canvas added practically nothing to their strength while hot. Wires pulled out from the canvas and held in an open Bunsen flame lost their strength instantly. This led Professor Warren to suggest that iron wire of, say, twenty-five or twenty-eight gauge, would prove a much greater addition to the strength of curtain cloth, but in the Chicago furnace tests I noted that iron wire, about No. 18, was rapidly oxidized in the gas flame.

The asbestos residue left after driving off the water is practically infusible and would doubtless adhere together, and being supported by the iron wire would form an effective screen long enough to permit escape and to restrain the progress of the flames while the firemen were coming. Wrought iron is less readily fusible than steel, but the steel wire would probably hold up to, say, 900° C., or $1,650^{\circ}$ F. Steel melts at $1,200^{\circ}$ to $1,300^{\circ}$ C.; pure iron about $1,600^{\circ}$ C.

I found the small iron stairway over the Iroquois stage showed effects such as are produced by red heat. Glass in the skylights over the Iroquois stage was fused, which indicates about 875° to 900° C., or $1,650^{\circ}$ F.

Steel Plate Protected by Asbestos Material.

In our Chicago furnace tests we also experimented upon sundry combinations of asbestos, asbestos felt and asbestic cement, with thin steel plate and combined with wire netting, the asbestos being placed on the stage side in the hope that it might shield the steel from the full heat and thus prevent it showing red hot on the auditorium side, while the steel would give strength. We had to suspend these tests because of some temporary trouble with

the gas supply to the furnace, but they were carried far enough to prove an endurance more than ample for their purpose as a shield while the audience is escaping, and it was plain to all who witnessed these tests that the sheet steel curtain, protected with some asbestic material on the fire side, possessed far greater strength and endurance against fire than the simple asbestos. The thin sheet of steel, moreover, cut off the view of the fire that was apparent through the texture of the asbestos canvas.

With care given to the design of the guides and fastenings at edges and top, so that after it was lowered the curtain could not be pulled out by warping, buckling, "smoke explosions" or pressure of air, the steel curtains would have a value to the fire underwriter that no asbestos curtain can possess, and would probably hold a fire on the stage from entering the auditorium.

The general type of steel proscenium curtain finally adopted in Chicago and required at all theaters was worked out somewhat hurriedly, according to the average judgment of the Aldermanic Committee, in advance of any other tests than the failure of the Iroquois curtain.

It consists of a light framework of steel angle irons with corrugated plate about one-sixteenth inch thick on the auditorium side, and some asbestic non-conducting material on the stage side, with an air space of one, two or three inches between. Where guided only by loops on stationary vertical cables at its vertical edges, it is required to lap over the edge of the arch about eight inches. A curtain structure of this kind of the ordinary size weighs from two tons to six tons.

The hanging of most of these Chicago steel curtains would be improved by more substantial iron channels to hold the edge, and by the addition of positive down-haul tackle or some arrangement by which the counterweight could be thrown off, for now the great weight of these curtains is so nearly counterpoised that it is entirely possible that the excess of air pressure against its surface of about one thousand square feet may prevent the slight excess of gravity from lowering it. The Austrian experiments and the story of some of the eye-witnesses of the Iroquois disaster indicate the possibility of a strong outward air pressure from the expanding air.

Finally, regarding fire curtains, it should be said that with proper smoke vents and complete automatic sprinklers, the perfection of the curtain becomes of lesser importance.

THE FIREPROOFING OF SCENERY.

Theatrical scenery is ordinarily painted on a strong linen canvas weighing about six and six-tenths ounces per square yard. Heavy cotton sheeting is sometimes used for the cheaper temporary productions. The gauze used for skies and transformation scenes is of cotton, of texture like mosquito-netting. Frames and battens and profile backings are of white pine. The canvas is first stretched on a frame and stiffened by a coat of glue size applied warm with a broad brush. Next, it receives a priming coat of whiting and glue size, and is then ready for the scene painter. The mineral colors used are mixed with water and glue, and many tests prove that the painted canvas is somewhat less readily combustible than the unpainted, and that the heavier is the coat of pigment the more flame is retarded.

The fireproofing of scenery canvas and other cloths and fabrics has from time to time, during the past fifty years, engaged the attention of many talented men, and one who now consults only the articles in books and technical pamphlets is led to believe that this fireproofing of canvas or cloth can be accomplished by brushing the surface over with either one of several solutions of chemicals.

After reviewing whatever I could find in print, after consulting with several experienced scenic artists, and after making tests myself, and later enlisting the friendly assistance of several experienced chemists to carry on independent investigations of all solutions prominently recommended for the fireproofing or flame-proofing of fabrics, I regret to conclude:

1st, that the best that is possible in the fireproofing of scenery is far from satisfactory;

2d, that the petty tests that have satisfied certain distinguished chemists are very misleading as guides to what will happen when the same process is tested on the larger practical scale;

3d, that the best we can hope to accomplish is to "flame-proof" a fabric so that it will not ignite from a match, an electric spark or a gas jet; or so that if ignited it will not burst into flame.

This much of protection, little and disappointing as it is, is of great value and worth all that a good process costs, if it can be

accomplished in practice without injury to fabric or colors; for if we can thus prevent the little flame from quickly spreading, we have removed perhaps nine-tenths of the danger of a fire starting on the stage, but it falls far short of what many have believed and loudly proclaimed was within easy reach.

Inefficiency of All Methods of Fireproofing Scenery.

Once get the gauze and canvas and pine on the stage enveloped in flame, everything "fireproofed" will burn to total destruction with substantially as great a rush of flame and suffocating smoke as with the untreated material. Indeed, the chemicals may make the fumes worse.

After having investigated the question of fireproofing the scenery faithfully, probably with greater thoroughness than has ever been done heretofore, I am led to believe that we must after all rely on the safeguards of the engineer rather than those of the chemist, for the safeguarding of human life in theaters.

The efficient fireproofing of the great quantity of white pine used in frames, battens and profiles (eight thousand square feet in the case of the Iroquois) appears to be a practical impossibility. The eleven miles of manila ropes cannot be "flame-proofed" without too great a sacrifice of their strength.

New Tests and the Theory of Action of "Fireproofing" Chemicals.

Distrusting the ordinary test of trying to ignite a small strip of the treated cloth with a match or gas flame, early in these studies I took about one-fourth a square yard of cloth treated with phosphate of ammonia, which is the most efficient fire retardant of all the half hundred chemicals and mixtures yet recommended, and hanging it in sheets half an inch apart within a piece of common stove pipe two feet long, lined with a sheet of asbestos in order to check the loss of heat by absorption in the cold metal, lighting it at the bottom with a little wad of "excelsior" wood shavings, I saw this "most perfectly fireproofed cloth" disappear with a rush of flame in forty seconds.

The difference in the results of a test of a single strip over a gas flame and a series of parallel sheets hung near together within a chamber is that in the second case we confine the radiant heat and the distilled combustible gases very much as they would be

confined in the closely hung sheets of scenery over the stage (see Figs. 1 and 2).

It is almost inconceivable that any of the various solutions used for fireproofing canvas or wood could so change the cellulose, gums and resins, of which these mainly consist, as to prevent their destructive distillation with the evolution of the same volume of inflammable gas, much like ordinary illuminating gas, that they ordinarily give out when heated to the char point.

We may find it slow work to light the wet twigs and green wood for our camp fire, but once well started, they burn furiously. The best fireproofing of fabrics amounts to about the same as substituting a fabric of wool for one of flax or cotton. Woolen mills by fifty years' experience are no better insurance risks than cotton mills.

Our various tests, interpreted from the scientific point of view, indicate that about all that we can hope for from the application of "fireproofing" chemicals is as follows:

1st, the destructive distillation of the chemical may keep the surface of the cloth near the applied flame bathed for a few seconds in a thin film of steam or inert gas, arising from the distillation of the microscopic quantity of the chemical lodged in the fabric, thus keeping the oxygen of the air away from the carbon for a moment.

2d, the dissociation or distillation of this little quantity of the chemical absorbs a little of the heat applied or evolved.

3d, the chemical used may have a non-volatile base which will fuse and cover the surface of the combustible carbon with a glassy film that, although exceedingly thin, will keep this carbon beyond reach of the oxygen of the air. This may perhaps lock up from twenty-five per cent. to fifty per cent. of the heat-giving content of the fiber.

I have already intimated that phosphate of ammonia has given the best record in fire-retardant quality of any of the many chemicals and mixtures tested. Theoretically, we should expect it to do so, for its chemistry fulfils the above conditions. First, it has a little tendency to gather dampness, and to dry this out absorbs a little heat. Next, as the heat rises, ammonia is given off, and the thin film of this repels the oxygen of the air. When the ammo-

nia is gone we have left the ortho phosphoric acid which in liquid form covers the surface and preserves it from oxidation under increasing heat. At 300 to 400 degrees Fahrenheit this decomposes, giving off water; at higher temperatures, it gives off its remaining water. In all of this dissociation it absorbs some heat until we have left, at full red heat, fused meta-phosphoric acid *as a liquid film surrounding the fixed carbon* remaining from the destructive distillation.

On the other hand, the phosphate of ammonia has its disadvantages. A manufacturing chemist, perhaps of widest experience of any in this country in the practical chemistry of the phosphates, warns me that for its best efficiency it must be applied in a strong or saturated solution, but if very strong, it may in time disastrously affect the strength of the fiber, that it is somewhat deliquescent, has a tendency to develop fungous growth, that in time it may part with a portion of its ammonia, becoming the acid ammonium phosphate which has a tendency in presence of moisture to attack metals, while in a warm atmosphere the free phosphoric acid attacks some colors.

The foregoing cautions by my friend, the chemist, were derived from experience on other material than stage scenery, and we shall soon have plenty practical experience to show if phosphate of ammonia is injurious to scenery, under the practical conditions of use, for this has been used during the past year and a half more than any other substance to meet the enforcement of the laws of certain cities requiring all stage scenery to be fire-proofed. The diluteness of the solution that has been applied in some instances within my observation will tend to lessen its injurious qualities in the same degree that it weakens its flame-proofing, and the tendency of any antipyrine to promote mildew in damp atmospheres can probably be prevented by adding some antiseptic or germicide to the solution.

History and Practice of Fireproofing Canvas.

After each of the great historic theater fires that have occurred since the science of chemistry was born, this subject of fireproofing cloth has been studied by chemists of eminence, and nearly all of the chemicals and compounds recently brought forward by scenic artists and dealers in painters' supplies are the same that have been recommended over and over again for the past fifty years.

The tests made from time to time for proving their efficiency have not copied practical conditions.

It is said that fifty years ago, after a serious fire in the Berlin Opera House, it was made the custom to soak the scenery canvas in a strong solution of alum; nearly fifty years ago a Parisian chemist carefully examined the subject of fireproofing scenery, and orders are said to have been issued that all stage scenery be impregnated with silicate of soda. Fifty years ago the value of phosphate of ammonia was recognized as an antipyrine. Forty-five years ago an elaborate series of researches was reported to the British Association for the Advancement of Science, embracing a great range of chemicals, with many tests for determining the most effective strength of solution to be applied. Nearly thirty years ago, after the Brooklyn Theater horror, some of the scenery in Wallack's Theatre in New York is said to have been fireproofed with tungstate of soda, and the well-known New York chemist, Dr. R. Ogden Doremus, called the attention of American theater managers to phosphate of ammonia. More than twenty-five years ago a committee of the British House of Commons took testimony on this matter of fireproofing scenery, and the manager of the Criterion Theater testified that he regularly used sodium tungstate in the preparation of new scenery. Curiously, our recent tests fail to show any great virtue in sodium tungstate as an antipyrine. Twenty years ago the London Society of Arts reported on fireproofing of stage scenery and reported that the scenery in nearly all London theaters was treated with some fire retardant preparation.

Twenty years ago a committee of the Franklin Institute of Philadelphia studied and reported on this subject, recommending sundry chemicals.

Eleven years ago Prof. Thomas H. Norton devoted to this subject his presidential address before the Section of Chemistry in the American Association for the Advancement of Science at the Brooklyn meeting, and made it appear that fireproofing of fabrics was easy.

Nevertheless, it is probable there was at the time of the Iroquois fire hardly a piece of scenery on a theater stage in the United States or England, or anywhere else, that had been subjected to fireproofing treatment.

The veteran manager, John B. Shoefel, tells me that from his experience with the French and English made scenery used in

the American tours of Bernhardt, Rejane, Mounet-Sully, Coquelin, Mary Anderson, Irving and others under his management, it is his confident belief that none of it was fireproofed. His experienced stage mechanic, William J. Kelly, confirms this and says further, that according to his personal experience on the stage of several London theaters, none of their scenery was fireproofed. The eminent scenic artist, Walter Bunnage, of Chicago, tells me that through personal experience in England and conference with scene painters from the Continent, he has found there was no general use in Europe of fire retardant solutions in the preparations of scenery.

A year ago Mr. E. O. Sachs, Secretary of the British Fire Prevention Committee, wrote me that there was then no requirement for the fireproofing of scenery by chemical solutions in the English law, and in his compilation of the Building Laws of European cities, in Vienna alone, do we find mention of fireproofing of scenery, and there very vaguely.

Thus, notwithstanding widespread belief, backed by much eminent authority that scenery could be readily flame-proofed, it has not been done.

Why Stage Scenery Has Not Been Flame-proofed.

In brief, the reasons are:

1st, it adds to the cost by an amount that may be estimated at from \$250 to \$500 for the average five-act drama, having 25,000 square feet of canvas, and adds two or three times this cost for a great spectacular piece. Seldom would flameproofing add more than five per cent. or ten per cent. to the cost of an outfit of scenery.

2d, there is a fear that most of the fireproofing chemicals injure the strength of the canvas.

3d, the scenic artists have feared the effect on their delicate colors.

4th, some of the chemicals proposed tend to rust and loosen the iron fastenings and tacks.

5th, most of the stage scenery in existence is traveling around the country, stopping only a brief time in one city, and it is a tedious matter for the local authorities to make certain that it has been fireproofed.

6th, the appalling theater catastrophes have come almost a

generation apart. The people and the officials have short memories for their lessons. Inspectors become easy about special laws which, passed under pressure of a great calamity, soon become dead letters.

7th, the general public is thoughtless and indifferent and runs its chance.

Therefore, at the present time, although since the Iroquois fireproofing has become a general rule, remembering the likelihood that in future as in the past the fireproofing of scenery will become neglected, we may all the more emphasize the importance of the perfected automatic smoke vent and of the automatic sprinkler and the other obvious safeguards.

A New Investigation of the Fireproofing of Fabrics.

After some preliminary trials, with the assistance of the chemical engineer of the Inspection Department of the Factory Mutual Insurance Companies and conferences with the experienced scenic artists, Burrage of Chicago and Story of Boston, and after reviewing the probable effect of various solutions upon the fabrics and upon the ordinary colors used by the scenic artist with some of my personal friends who were of wide experience as chemists of textile factories and chemical works, I enlisted the ingenuity of my friend, Mr. George C. Whipple, Consulting Engineer, Director of the Mt. Prospect Laboratory in Brooklyn, and of Mr. Irving W. Fay, Professor of Chemistry in the Brooklyn Polytechnic Institute, in the hope that *starting with the theory of the successful action of ammonium phosphate*, as stated above, we could find some substance of equal value as an antipyrine that would be less likely to injure fabric or colors. Sundry theaters and scenic studios were visited by Mr. Whipple to learn the practical conditions. The bibliography of the subject was again thoroughly reviewed. Standard methods for testing the comparative efficiency were worked out, and tests were made with substantially all of the substances that had been recommended by good authorities.

Nothing was found better than, or so efficient as, the phosphate of ammonia, known to be efficient for the past fifty years. *Nothing was found that would prevent the instant burning with a rush of flame when the test was made with a strong blaze on closely hung sheets of canvas*, but many substances were found

that would make gauze and canvas proof against ignition by a match, flame, gas jet, a cigarette or an electric spark.

Some Tests of Effect of Fire-proofing Solutions upon Colors.

In my Boston tests the results of sundry solutions, after from one month to one and one-half years' time, upon canvas sized and painted in the ordinary way with the ordinary colors of the scenic artist's palette, was as given in Tables 4 and 5 (pages 127 and 128), which are representative selections from eight large test sheets:

These eight samples were prepared in the studio of Mr. Story, a well-known scenic artist of Boston, under the supervision of Mr. L. K. Davis, chemical engineer of our Inspection Department. Sheets of ordinary linen scenery canvas and also sheets of wide cotton such as used for scene painting, each about seven feet square, were painted with broad flat stripes of the colors found commonly in the scene painter's palette—put on by an experienced artist in the ordinary manner. After these strips of color were thoroughly dry other broad stripes, crosswise to the first, were applied, consisting of one stripe each of the various chemical solutions which at that time were most prominently commended for fireproofing scenery. This checker-board pattern thus permitted about 180 simultaneous tests of color and chemical on each of our eight large canvas sheets, or more than 1,000 in all.

Solutions of different strength were tried on different sheets, 15 per cent. and 25 per cent. respectively, and the further experiment was made of first applying a strong solution of each chemical to the canvas before it was sized and painted. This gave much better results and far less discoloration than when the canvas was flame-proofed after it had been sized and painted.

The reason for the less discoloration plainly is that the chemical penetrates the fiber more easily before it has been sized, and that the sizing prior to the painting locks it in and puts it into less intimate contact with the pigment.

I found, in every case, that the phosphate of ammonia affected many of the colors, and that the ammonium chloride and the strong solution of "fireproofine" were very injurious.

The treated canvas when dry and shaken gave off a dust from the chemicals.

To independently verify and extend the above tests that the

TABLE 5.—EFFECT OF FLAME PROOFING SOLUTIONS UPON SCENE PAINTERS' COLORS.

These Solutions Contained Each 25 per cent. by Weight of the Given Salt.

	ON ORDINARY LINEN CANVAS.					ON HEAVY COTTON SHEETING.				
	Ammonium Phosphate. A	Ammonium Sulphate. B	Ammonium Chloride. C	Aluminum Sulphate. D	Sodium Tungstate. E	Ammonium Phosphate. A	Ammonium Sulphate. B	Ammonium Chloride. C	Aluminum Sulphate. D	Sodium Tungstate. E
1. Chrome Yellow.	Dirty gray.					Dirty gray.	Slightly darker.	Dark, muddy.		
2. Yellow Ochre.	Very slightly darker.					Slightly darker.	Darker.			
3. Dutch Pink.	Whitens slightly.					Slightly darker.	Darker.			
4. Raw Sienna.	Slightly muddy.					Slightly darker.	Muddy.			
5. Orange Mineral.	Very much darker.					Very much darker, muddy.	Very muddy.	Turns dark brown.		
6. Venetian Red.			Turns Dark Brown.							
7. Burnt Sienna.										
8. Rose Lake.	Efflorescence. Turns Orange.					Darker red and blotchy.	Darker, muddy. Slightly orange.	Turns dark red.		Much darker. Turns bright orange.
9. Am. Vermillion			Turns Dark, muddy Red.							
10. Black.										
11. Burnt Umber.										
12. Raw Umber.										
13. Celestial Blue.	Cracks White. White Cracks.					Slightly darker. Muddy blotches. Muddy blotches.	Much darker. Slightly darker. Darker in blotches.			
14. Cobalt Blue.										
15. Italian Blue.										
16. Chrome Green.	Slightly darker.									
17. Flake White.	Turns Yellow.									
18. Whiting.										
	(Spotted) shows white cracks or streaks of efflorescence. Where canvas has been rolled slightly changes nearly all colors.	Very slight changes. Slightly bleaches Am. r. Vermillion. Slightly darkens Chrome Green and Cobalt Blue.	(Spotted) darkens Chrome Green.	Very slight change except some efflorescence and makes the blues muddy.	No change in color except bleaches Am. r. Vermillion and makes Rose Lake dark and muddy, but gives White efflorescence, cracks. Nos. 13 to 16. Also No. 6. Also turns the Whiting yellow.	Injures a majority of colors, making them muddy.	Turns a majority of colors darker.	Spots nearly all the colors, making them much darker.	Very slight change except darker blotches on 8, 11, 12 and 13.	Slight changes except in Rose Lake and Am. r. Vermillion.

chemical engineer of our Inspection Department had made in a Boston scenic studio, Messrs. Whipple and Fay tested about thirty-five colors and shades by painting these colors in stripes on a sheet of canvas, and there crossing them with stripes of the various fire-proofing solutions. In the brief tests by Whipple and Fay no colors were found affected by the solutions commonly used save the cobalt blues and the delicate violets, thus differing somewhat from the results of my previous tests at Boston in which I found many of the standard scene painters' colors affected by phosphate of ammonia and ammonium chloride to the extent of changing the shade or tint, and in extreme cases destroying the color, and had found that samples of painted scenery treated with a trade preparation called "fireproofine" became marred by a dusty white efflorescence.

Possibly this efflorescence is to some extent a matter of manipulation, and the decision about injury to colors, as suggested regarding the promotion of mildew, had best be made after we are all possessed of the result of a few years' experience with the present legal requirements for fire-proofing scenery in practical use and with solutions of the strength actually applied. What little I have seen of men at work on fireproofing scenery leads me to fear that in order to avoid discoloration and efflorescence, the solutions will be put on too weak for the best flame-proofing, and that after the Iroquois is a little further in the past, most of the scenery will no longer be treated for flameproofing.

This effect of antipyrine chemicals upon colors is a question for the chemist rather than the engineer, and it is quite possible that a full range of the necessary colors could be worked out from pigments that would not be changed by the flame-proofing liquids, particularly if the antipyrine chemical be applied to the new canvas before sizing.

The Whipple and Fay Investigations on "Fireproofing" Scenery.

Mr. Whipple and Dr. Fay gave much time to testing the relative efficiency of various solutions and to developing standard methods of test, by which the relative efficiency of one fire retardant solution could be compared with another, and their work is so complete and instructive that I regret I can present here only a summary of it.

The following brief outline will show its general scope.

The results may be summed up as follows:

(1) Phosphate of ammonia was found the most efficient antipyrine.

(2) Tungstate of soda, so often found recommended in the text-books, was found to possess almost no value.

(3) The various proprietary solutions when analyzed were found to be all based on one or another of the ammonium salts, commonly the phosphate, but frequently the cheaper sulphate substituted in whole or in part.

(4) Linen canvas or cotton cloth, fireproofed in the best manner possible by any of these solutions, could be quickly burned to total destruction if a sheet were rolled in a loose coil with the axis vertical and a space of perhaps one-half an inch between the folds, and a fire then lighted with a small wad of excelsior at the bottom of the roll; this method of test serving to confine the radiant heat and the gases distilled from the fiber. This was of special interest since strips of the same cloth tested in the manner that has satisfied previous experimenters—by holding the strips of treated cloth vertically over an ordinary Bunsen flame—could not be ignited and appeared almost perfectly flameproof.

(5) The most efficient part in the fireproofing of fibers was found performed by the covering of the fiber with a non-volatile liquid that excluded the oxygen. Phosphoric acid proved better for this purpose than any other substance tested, but obviously could not be applied alone because of its corrosive action on fibers and colors.

(6) The ammonium in combination with it in phosphate of ammonia was found of value chiefly in locking up the corrosive qualities of the phosphoric acid until released by the heat of the fire, and thus giving a comparatively harmless compound for application to color and fabric.

(7) The method of application of the fireproofing solution to the canvas was found to have great influence on the degree of fire protection secured. One of the best solutions, when brushed cold over the back of old scenery, penetrated the fiber so little as to be of no value, but when applied hot was efficient. Under some conditions the linen canvas is repellent of water, as one finds on trying to dry the hands on a new crash towel. When the liquid is applied rapidly

to a vertical surface with a brush, linen cloth does not absorb it readily. Hot application or the solution adds much to its efficient penetration of the fiber. For new scenery, probably the best method is to saturate the canvas between rollers in a bath. The next best method is to mix the chemicals with the water of the glue size that the scene painter puts on before painting his picture.

(8) Tests of the tendency of the various chemicals to induce decay were made by sowing some of the treated samples with mold spores. Other tests were made by adding various per cents. of phosphate of ammonia to nutrient gelatine and to mixtures of the glue size, and incubating these for tests of bacterial growth.

(9) The effect of the solutions on the colors ordinarily used by the scenic artist was not found bad, except in case of some of the more delicate blues and greens, but a greater length of time would be necessary before positive statements about this can be made.

(10) When canvas that has been flameproofed is actually burned as it may be under practical conditions, it gives off fumes that may be even more dense and suffocating than those from the untreated canvas.

Proof that the Kind of Paint Used on Scenery Makes it Less Readily Combustible.

At the beginning, Messrs. Whipple and Fay made tests of the comparative combustibility of old painted scenery canvas with new unpainted canvas by taking strips all of the same size, thirty inches high by three inches wide, and burning them while hanging vertically from a nail, in a box that shielded them from cross drafts of air. The specimens were all lighted at the bottom and all under similar conditions.

TABLE 6.

Specimen No.	Original Weight of Sample Grains.	Time of Burning, Seconds.	Weight of Pigment Compared with Unpainted Canvas.
0	11.0	30	40 %
1	16.1	35	48 %
2	18.7	42	61 %
3	24.1	58	121 %

In No. 3 the paint was heavier than the canvas.

It will be noted the retardation of the flame was proportional to the amount of paint. The flames reached a maximum height of one and five-tenths feet.

Order of Experimenting on Effect of Various Antipyrines.

The general course of the subsequent experimenting followed by Whipple and Fay, stated briefly, ran as follows:

As a preliminary experiment, strips of cotton cheese cloth were dipped in various saturated solutions, and after drying were held in a Bunsen flame. The substances were thus quickly proved as to relative efficiency as follows: the ammonium phosphate in saturated solution proving most efficient of any.

Full notes, which I will not take space to reproduce here, were made of the behavior of each sample as a guide to further tests.

Relatively Poor Results.

Common salt.
Boric acid.
Borax.
Borax $\frac{1}{2}$ and sodium sulphate, $\frac{1}{2}$.
Sodium phosphate.
Sodium sulphate.
Sodium tungstate, 15% sol.
Bicarbonate of soda.
Ammonium sulphate, half sat. sol.
Ammonium phosphate $\frac{1}{2}$, and sodium sulphate $\frac{1}{2}$.
Aluminum sulphate.
Potash alum of various strength of sol.
"Paris Theater solution."
"Subrath's Formula."

Relatively Fair Results.

Ammonium chloride.
Martin & Tessier's formula.

Relatively Good Results.

Ammonium phosphate.
Phosphoric acid.
Borax $\frac{1}{2}$ and ammonium sulphate $\frac{1}{2}$.
Ammonium sulphate.
Calcium chloride, 25% sol.
"New Paris solution."

Next, explanation was sought of the reason for the behavior of the various fireproofing compounds.

Points in Theory of Flameproofing Established by the Whipple and Fay Tests.

(1) The influence of the water of crystallization in retarding ignition was studied. It was found that although different samples of cloth treated respectively with alum, borax and sodium tungstate and each loaded with all it could carry, the large amount of water of crystallization in these salts did not make them efficient fire retardants. The subject was studied further by selecting two salts, both compounds of the same phosphoric acid, but one possessing twelve molecules of crystal

water, or over sixty per cent., while the other possessed none; sodium phosphate and ammonium phosphate being chosen. The chemical reactions were studied through the successive stages, and the relative effect judged by weighing the amount of char left after ignition of the treated cloth. *It became plain that water of crystallization played a much less important part than the fluid, varnish-like residuum.*

(2) Tests were then made for learning of the influence of the ammonia given off from the phosphate of ammonia when heated by comparing the effects of potash alum and ammonia alum. The ammonia alum proved somewhat the better, indicating that the evolution of ammonia had some small value.

(3) Tests were made to learn of the efficiency of the phosphoric acid left from heating the phosphate of ammonia by starting with canvas treated with phosphoric acid. The phosphoric acid proved nearly as efficient a fire retardant as the phosphate of ammonia. *The chief value of the ammonia in the phosphate of ammonia appeared to be the rendering of the phosphoric acid less harmful to canvas and colors.*

(4) A study was next made of the absorption of heat by the volatilization and decomposition of the fireproofing salts, and it was, for example, made apparent that the number of thermal units absorbed in driving out the combined water from a given weight of ammonium chloride was nearly four times as great as for an equal weight of sodium phosphate, and this helps make clear why ammonium chloride has flameproofing qualities of some value, while the sodium phosphate is comparatively worthless for this purpose.

(5) A study was then made of the combustible quality of the gases distilled off when canvas that had been treated by various flameproofing compounds was ignited, in order to learn if inert gases derived from the chemicals used for flameproofing diluted the combustible gases from the cellulose, to the point where the combined gases would not ignite. For this purpose little rolls of linen untreated, and treated by various chemicals, were heated to destruction separately in glass ignition tubes, five-eighth of an inch diameter x 6 inches long, placed with the end in a muffle, heating the muffle by gas to a temperature which, judging by the color, was from one thousand degrees to twelve hundred

degrees Centigrade. This temperature, as shown by the color, was maintained nearly constant all through these ignition tests.

These test rolls were two and one-half inches long and lay only within the uniformly heated zone at the bottom of the test tube. The distilled gas issuing from the end of the test tube was ignited. The progress of the charring of the canvas could be observed through the glass tube. The relative amounts of tarry matters condensed at the cooler, outer portion of the tubes was also compared.

It was found that canvas, flameproofed so that a strip of this canvas could not be made to ignite from a Bunsen flame, would, when tested in the ignition tube, not give off ignitable gases from the tube. The rapidity and simplicity of the ignition tube test were found such as to commend it.

Therefore, series of tests with the whole line of known efficient fire retardant compounds was made in this manner, and full notes of their behavior kept.

As a result of the tests thus far, it was concluded in brief:

(a) That inert chemical substances can exert but very slight fire-retarding action.

(b) The fire-retarding action of salts which depend for fire-retardant quality only upon their water of crystallization, like potash, alum, sodium phosphate and borax, is slight and unimportant, although somewhat superior to that of inert substances.

(c) Fire retardants of the class which suffers chemical decomposition under heating are decidedly more efficient than those which depend on the driving off of water of crystallization, but still far less efficient than the class that follows.

(d) *The most efficient salts are those which on decomposing leave behind a non-volatile residue which is fluid at the temperature of the burning canvas, and covers the charring fabric with a thin glaze which prevents further access of air, and of this type, phosphate of ammonium was found to be the best.*

Analyses of Sundry Proprietary Fireproofing Solutions in Use in 1904 to Meet the Recent Requirements of the New York Building Law.

The following table gives the result of chemical analysis of the most prominent fireproofing solutions found at that time on sale

in the New York market for the purpose of fireproofing scenery:

	Grams per 100 Cubic Centimeters.							
	Total Residue.	Ammonium Sulphide.	Ammonium Phosphate.	Ammonium Chloride.	Sodium Sulphate.	Borax (Crystals).	Boric Acid.	Sodium Tungstate.
1. Fireproofine.....	6.3	1.5	2.5	2.3*
2. H. S. Fireproofing Solution.....	16.5	12.6
3. Electric.....	24.5	17.0	9.7
4. H. W. Johns' Compound.....	16.7	10.7	5.3
5. No flame.....	15.5	8.4	5.0
6. Blenio Solution.....	20.7	3.7	15.6	1.4
7. Salamanderine.....	17.4	8.1	5.8	3.6
8. Antipyros Klugiana.....	23.9	18.5	2.0	1.0	2.5
9. Van Ripper Solution.....	present
10. Lamb & Finlay's prepared canvas.....	present	present

* Combined as glyceride, 3.9 grams per 100 C.C.

Tests were made on scenery canvas that had been treated, *the fabric being thoroughly impregnated* by soaking and wringing out or by brushing on both sides of the heavy canvas, with each of the foregoing, both in the Bunsen flame and in the glass tube in the furnace; all of them were found to be fairly efficient, Nos. 9 and 10 being perhaps the least so. It should be noted that *the cloth tested was more thoroughly impregnated than old scenery will be when brushed over on the back at a single application*. Those solutions containing the larger amounts of ammonium phosphate were found the most efficient. The only apparent advantage of the chloride or sulphate of ammonium is the fact that it costs only half as much as the phosphate; it is less efficient.

Sodium sulphate, boric and boric acid are present in some of the solutions. These were found to contribute relatively little to the flame-resisting power, and the sodium tungstate came to be regarded by these chemists as worthless for this purpose.

U. S. Patents on Fireproofing Solutions.

Previous to the investigations made for me by Messrs. Whipple and Fay I had procured from the U. S. Patent Office a complete file of the patents issued during a period of about 30 years, for the purpose of studying them for suggestions as to chemicals or processes to be used. I found in them nothing of particular interest. The compounds in most cases were made up by mixing one and another of the salts, alum, phosphate of ammonia, borax, sulphate of ammonia, etc., that have been in common use and recommended over and over again for 50 years,

the novelty consisting in the precise formula for proportioning the mixture and in the selection of ingredients. Alwin Nieske, of Dresden, Germany, however, went somewhat outside the beaten path in patenting in 1901 molybdate of sodium in a 10 per cent. solution for application to fabrics for fireproofing and preserving them. In general, fabrics other than theatrical scenery appear to have been in the mind of these patentees, and the number of patents for fireproofing textile fabrics is not nearly so numerous as for the fireproofing of wood.

Difficulty of Proper Application of Fireproofing Solutions.

In the foregoing tests the effort had been to test the efficiency of the solutions, it being assumed they would all be most thoroughly applied.

The method of application of fire-proofing solutions was next made an object of study by Whipple and Fay. Samples of old scenery were subjected to treatment by the various more efficient solutions in different ways, and finally in order to produce uniform results and ensure the uniform distribution, *application was made by immersion in a bath* containing submerged rollers, while dipping, followed by a wringer with rubber rollers was used as an alternative method.

It became plain that the method of application and the thoroughness with which the solution was absorbed had much to do with efficiency. In order to completely saturate the fibers, many dips and wringings were found necessary. The glue size of the unpainted back of scenery canvas prevents to a considerable degree the rapid penetration and absorption of the liquids applied. Under rapid application with a brush, the best of the solutions may fail to render the canvas flameproof, particularly if applied cold.

No inspector can tell from the appearance of one of these large sheets of canvas whether the solution has been properly applied all over its surface, and probably all that inspection will ordinarily amount to in practice will be equivalent to what would be shown by the touching of a lighted match to the edge of the canvas sheet.

As to the permanence of the residue left in the canvas, it was noted that when cloth that had been treated by one of the best

f the fireproofing solutions was shaken and brushed, the white powder could be shaken off in the form of dust, and that more was removed by brushing. This indicates that although a freshly treated canvas may be well flameproofed, it may lose this quality to a noteworthy extent after the rough usage which scenery received on the stage and on the road. It would be interesting to follow this matter further by tests of pieces taken from the margins of scenery that had been treated, and then had one or two years of travel and use.

Mildew.

It has been claimed that the application of fireproofing solutions weakens the canvas. If true, it is important to know whether this comes from slow chemical action or from the rotting of fiber due to bacterial action or mold, since in the latter case a germicide could perhaps be incorporated in the solution.

Tests of effect of certain fireproofing compounds in promoting mildew and mold were made; first, by adding varying percentages of ammonium phosphate to nutrient gelatine which was then exposed and incubated by methods common in bacteriological work, and, secondly, by seeding the worst treated canvas with mold spores. Time was lacking to carry these tests to the desired length, but so far as they went it was found that the glue used to size the canvas is probably a more potent promoter of mildew than the salts employed for fireproofing. Concentrated applications of the fireproofing salts will doubtless retard these organic growths, while dilute applications of some of the salts, phosphate of ammonia, for example, will very likely stimulate mold and bacterial decomposition, particularly if hygroscopic. Time did not permit the working out of experiments to find a suitable germicide for addition to the solutions.

The Fireproofing of Wood.

Since the pine frame work of the set pieces and wings present a greater quantity of fuel than the canvas itself, it would be desirable to flameproof this wood. A simple brushing over with phosphate of ammonia or other chemical solutions is found inefficient.

Various processes for making wood fireproof have long been known and have been used on wood for interior finish and trim

of fireproof buildings, more here in New York City than anywhere else, because of certain favoring clauses in its building laws.

The various tests made by Professor Norton of the Massachusetts Institute of Technology * and others have shown that, although the wood, after treatment, is much less readily ignited from a small blaze, as from a match or an electric spark, *no real fireproofing results*. Previous tests have covered this matter so thoroughly, and have shown the loss of strength and tendency to gather moisture and other objectionable qualities that follow treatment, that I gave little attention to testing this matter further, but rested mainly on the tests of previous experimenters. I obtained sundry specimens of wood that had been fireproofed in the commercial way from two prominent shipyards that had war vessels under construction and I made a few simple tests.

Fireproof wood was at one time much used on the war vessels of the Navy, but has been almost wholly abandoned by reason of its gathering moisture badly and the lessening of strength and the increased difficulty of working it.

The frames of scenery must be particularly light and strong, and the wood must possess its maximum strength, and should not be liable to warp. I do not find that "fireproof" wood has ever been used practically for this purpose at any theater, in this country or abroad, notwithstanding the activity of its promoters. I soon concluded that in the present state of the art it was too much to expect that the wood flameproofed by any of the ordinary commercial processes could come into general use for battens, frames, profiles, etc., of stage scenery.

* See "Report on Fireproof Wood," so-called, by Prof. C. L. Norton, August, 1902.

Professor Norton summed up the results of his tests on samples of wood "fireproofed" by three of the more prominent commercial processes as follows :

"Fireproofed wood is almost identical with untreated wood in the following particulars:

- "It smokes at about the same temperature.
- "It can be ignited at about the same temperature.
- "It will continue to burn in many cases.
- "It is a good fuel.
- "It makes a very hot fire."

The ordinary method of test of little samples in the flame of a laboratory lamp tends to greatly exaggerate the extent of protection against fire gained. A better test is to make a small long vertical box of the wood, open at top and bottom, and let this serve as a chimney for a small fire kindled inside at the bottom.

“Fireproof” Paints.

“Fireproof paints” are sometimes required by law to be applied to wood-work about the stage. The underwriters’ laboratory at Chicago had a short time previously made an extensive series of tests of all of the prominent ones in the market. The unpublished records were placed at my service. These tests had shown that none of these paints had any noteworthy value in flame-proofing wood, but for confirmation I requested Messrs. Whipple and Fay to make tests of a few of those most prominent in the market. They purchased commercial samples and made chemical analyses of several; each was found to be mainly a sort of whitewash consisting of slaked lime, finely pulverized asbestos, with also a little alum, gypsum and glue. The paint adhered well when applied to canvas, but was quickly proved by test to have almost no flame-proofing quality whatever.

It is difficult or impossible, on precise scientific grounds, to see how these paints can have any noteworthy value against anything but a very small momentary blaze, like that of a match or spark.

None of these paints were found to penetrate below the surface of the wood as phosphate of ammonia, for example, penetrates into the fiber of cotton or linen cloth.

Obviously, so thin a film can have only exceedingly small effect as a non-conductor of heat. Radiation or contact must char the wood beneath almost as quickly as if the paint were not there. The destructive distillation will give off gas which will push out, blister, and peel off the paint, and this gas will burn.

In the “asbestos paints,” the pulverized asbestos, glued into a thin crust less than $\frac{1}{100}$ inch thick, can obviously be of no more fire retardant value than so much carbonate of lime or clay. The special value of the asbestos in paints is chiefly as a name to conjure with in attracting purchasers.

From all these tests a common lime whitewash appears to be as efficient a fireproof paint as anything yet found in the market.

DEVELOPMENT OF STANDARD METHODS OF TEST OF FLAMEPROOFED FABRICS.

Finally, much attention was given to devising a standard method for testing the relative efficiency of various chemicals

used for the flameproofing of scenery canvas. It has already been explained that no fireproofing of cloth is effective against severe heat, but it was plain, from the preliminary trials, that some of the solutions were much better than others in protection against a little blaze like that from a match, a cigarette or an electric spark.

Since all samples, however flameproofed, were destroyed by a severe test, all of these tests, of necessity, had to be merely comparative, and canvas treated with a saturated solution of phosphate of ammonia thoroughly worked into the fiber was adopted as the standard of comparison.

The "Stovepipe" Test.

In the effort to more nearly follow practical conditions, one set of tests was developed on the line of my earlier stovepipe experiment by burning fireproofed canvas within a piece of five-inch stovepipe two feet long lined with asbestos, as shown in Figs. 10 and 10a. Six strips of the canvas, thoroughly treated with the different solutions, were placed three-fourths of an inch apart and ignited by burning one ounce of excelsior. *In every case the canvas burned completely to ash in from three-fourths of a minute to one and one-half minutes, with flames which often extended two feet above the top of the stovepipe.* Tests in the stovepipe apparatus on the efficiency of different flameproofing chemicals were made comparable by taking the same quantity of canvas in each and by lighting the fire with the same quantity of combustible.

In the first efforts to standardize the "stovepipe test," it was found, after considerable experimenting, that by using a piece of the untreated canvas eight inches high by three inches wide for a kindling piece, and pinning this to the bottom of a strip of the flameproofed canvas sixteen inches long hung from the top, the flames from the kindling piece would barely reach to the top of the pipe, and as ammonium phosphate had proved the most efficient of the chemicals used in previous tests, the behavior of a strip of canvas thoroughly impregnated with this was taken as the standard for comparison.

The height of flame did not prove a good basis for comparisons because of the varying weights and thickness of canvas and the varying amounts of glue and paint applied. The amount of char

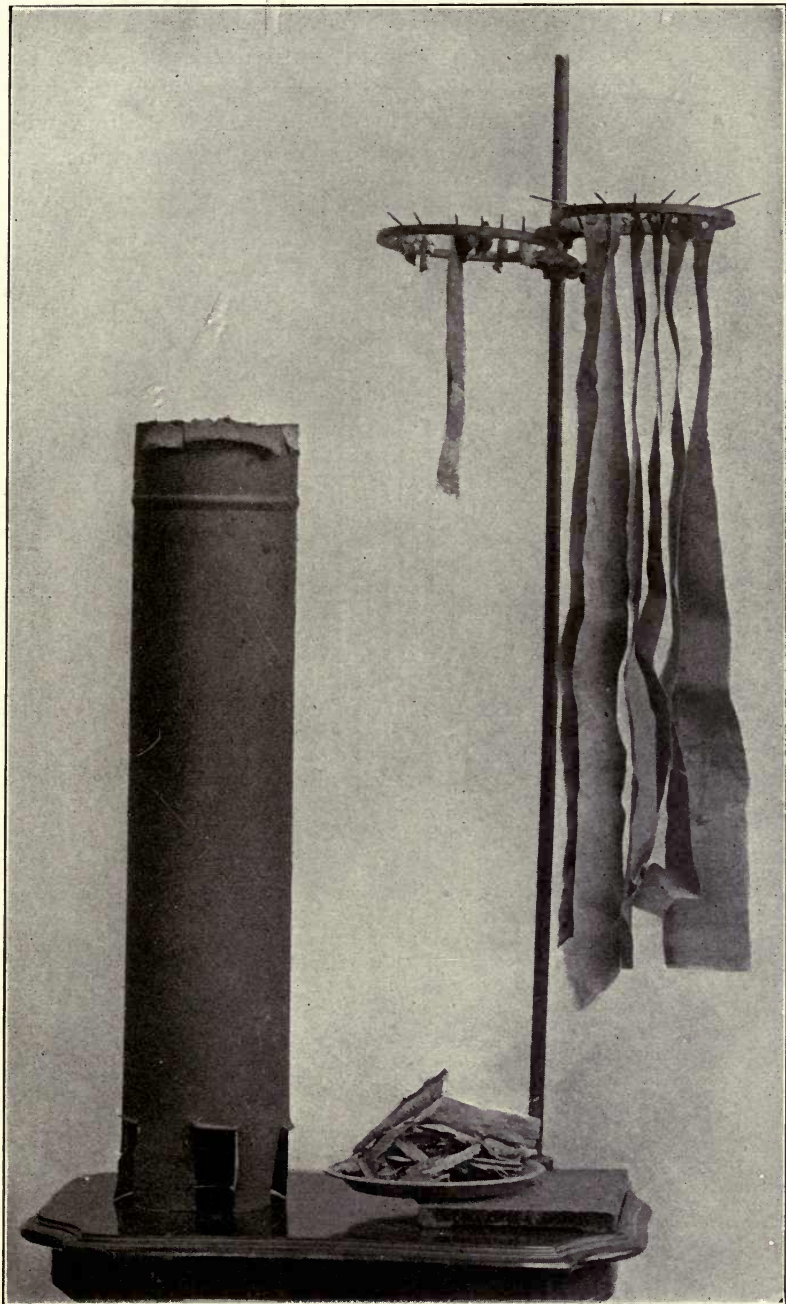

FIG. 10.—THE "STOVEPIPE" TEST OF SCENERY CANVAS.

produced was found the best basis of comparison. A strip thus prepared and lighted by the strip of untreated canvas, as above described, is for a short time bathed in flame from the burning of the strip below. A single strip thus tested alone, when taken out of pipe, is found with its lower end blackened and

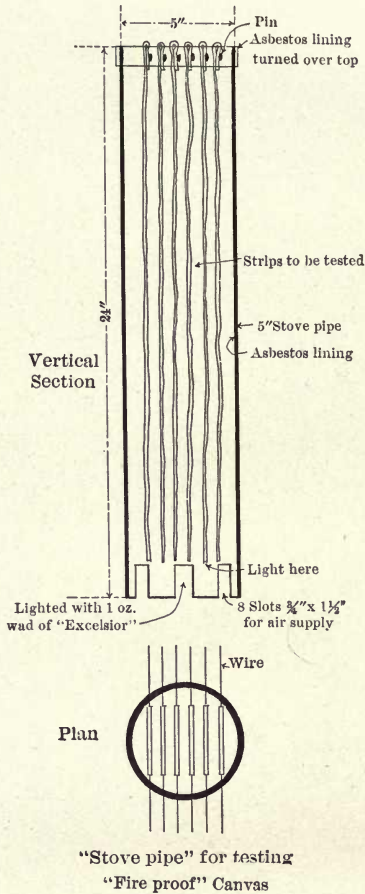

FIG. 10A.

charred up for about half the length, and the upper end white and unscorched, but on *placing several flame-proofed strips side by side* in the stovepipe, *all were consumed*.

In the following tests (see Tables 7 and 8) six strips of canvas thoroughly treated were placed side by side, three-fourths of an inch apart, and ignited by burning one ounce of excelsior.

In each case all was burned to ash in from forty-five seconds to ninety seconds with flames which often extended two feet above the top of the pipe.

Fig. 10 shows a photograph of the apparatus and Fig. 10A a sectional drawing of it. The little material left hanging upon the ring at the left of the retort stand, with the charred material on the tray beneath, shows what remained from one of these tests. On the ring at the right are shown the strips as prepared for insertion in the pipe.

TABLE 7.—STOVEPIPE TEST ON NEW UNPAINTED FIREPROOF CANVAS.

Solution Used.	Weight of Strip of Canvas before Testing (Grams).	Weight of Ash Remaining (Grams).	Weight of Substance Consumed (Grams).	Per Cent. of Substance Burned.
Borax.....	52	0.7	51.3	99
Ammonium chloride.....	62	0.5	61.5	99
Sodium phosphate.....	58	1.5	56.5	97
Aluminium sulphate.....	62	3.0	59.0	95
Ammonium phosphate.....	72	23.0	49.0	68

It will be noted that the ammonium phosphate gave the best result.

TABLE 8.—STOVEPIPE TEST ON OLD FIREPROOFED SCENERY.

Solution Used.	Weight of Strip of Canvas before Testing (Grams).	Weight of Ash Remaining (Grams).	Weight of Substance Consumed (Grams).	Per Cent. of Substance Burned.
* a. Chicago Solution.....	78	18	60	77
† b. Ammonium Sulphate.....	77	21	56	73
‡ c. Ammonium Sulphate.....	16	5	11	69
d. Ammonium Phosphate....	102	40	62	61
(1) Fire Proofine	136	64	72	63
(2) H. S. Compound	91	23	63	69
(3) Electric	101	35	66	65
(4) H. W. Johns'.....	91	28	63	69
(5) No Flame	93	36	57	61
(6) Blenio	97	30	67	69
(7) Salamanderine.....	94	27	67	71

Here, with the old painted scenery, as in the series just above with new canvas, nothing was found better than the ammonium phosphate.

This test, although so simple, is so severe that the specimens show little difference in quality of the fireproofing.

The per cents. in this table do not strictly represent the fire-retarding action, since the per cent. is figured on the original weight, including the incombustible mineral pigment.

* Ammonium phosphate, ammonium sulphate, ammonium chloride, borax and boric acid.

† On old scenery like the others, except c.

‡ On gauze.

Lamp Tests of Flame-proofed Scenery.

Although no solution found would protect the canvas so that it could withstand a severe test, it appeared desirable to devise some simple portable standard means of comparing the efficiency of various trade solutions with that of the standard phosphate of ammonia thoroughly worked into the fabric—something that an inspector of the city building department could use on his round for finding out if the law which requires flame-proofing of scenery canvas has been complied with, if he desired something more like apparatus than a box of matches or a plumber's gasoline

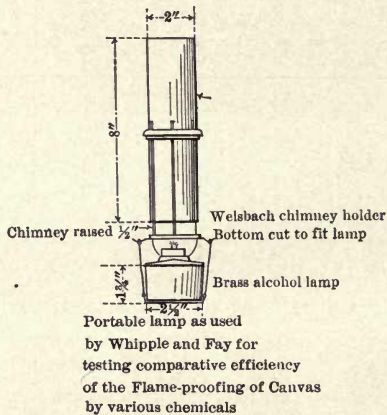
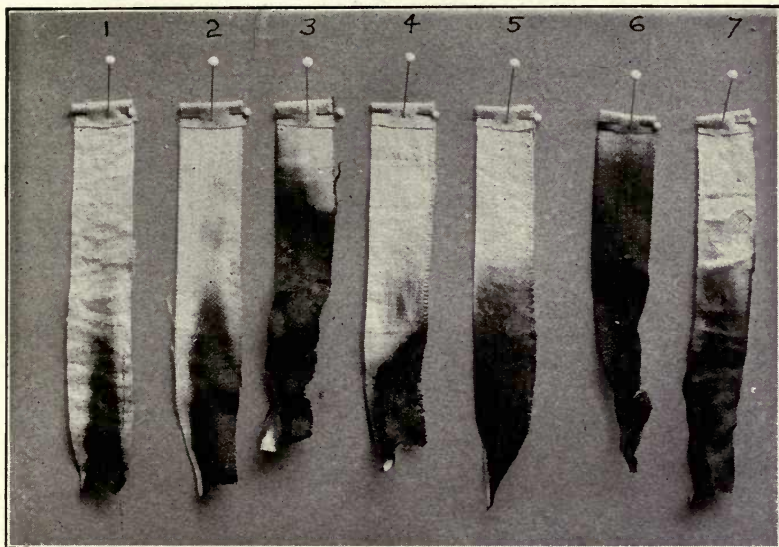

FIG. 11.

torch, or something that would permit a more definite record of the degree of resistance.

The testing lamp finally adopted by Messrs. Whipple and Fay is shown in Fig. 11.

The apparatus consists of a common alcohol lamp two inches high, two and one-half inches in diameter, fitted with a Welsbach chimney holder. The chimney served to protect the flame from side drafts, and thus to some extent prevented the dissipation of the gases. The chimney also served to support the sample and keep it in a central position over the flame. The chimney was raised half an inch above its seat in order to allow air to enter freely. The strips to be tested by the lamp were cut eight inches long and one inch wide. Each strip was folded over one-half inch at the top, so as to allow a slender wire to be passed



- 1. Ammonium Phosphate.
- 2. Antipros Klugiana.
- 3. Subrath's Formula.
- 4. New Paris Solution.

- 5. Martin & Tessier's Solution.
- 6. Salamanderine.
- 7. "No Flame."

FIG. 12.

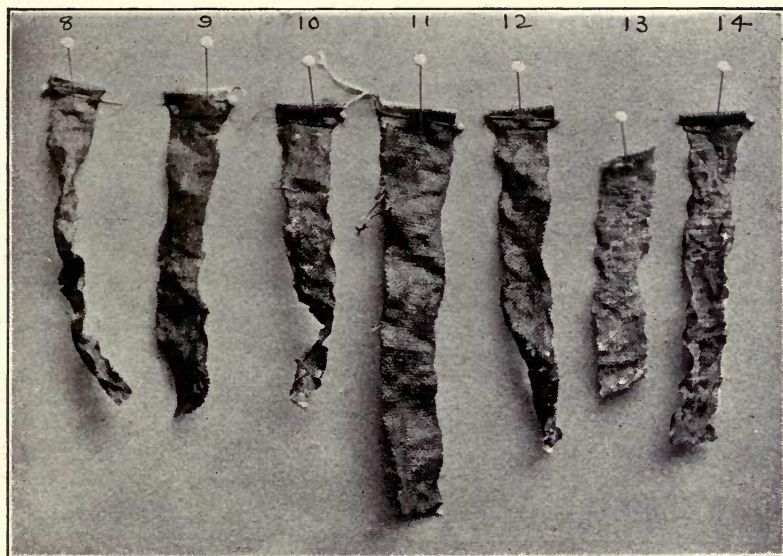

- 8. "Electric Fireproofing Solution."
- 9. Fireproofine.
- 10. Sodium Tungstate.
- 11. Boric Acid.

- 12. Ammonia Alum.
- 13. Som Phosphate.
- 14. Potashditu Alum.

FIG. 12A.

FLAME-PROOFED CANVAS STRIPS ONE INCH WIDE AFTER TEST OF ONE MINUTE IN ALCOHOL LAMP FLAME TWO INCHES HIGH, SHOWING COMPARATIVE EFFICIENCY OF VARIOUS "FIREPROOFING" CHEMICALS FOR PREVENTING IGNITION BY A PETTY FLAME.

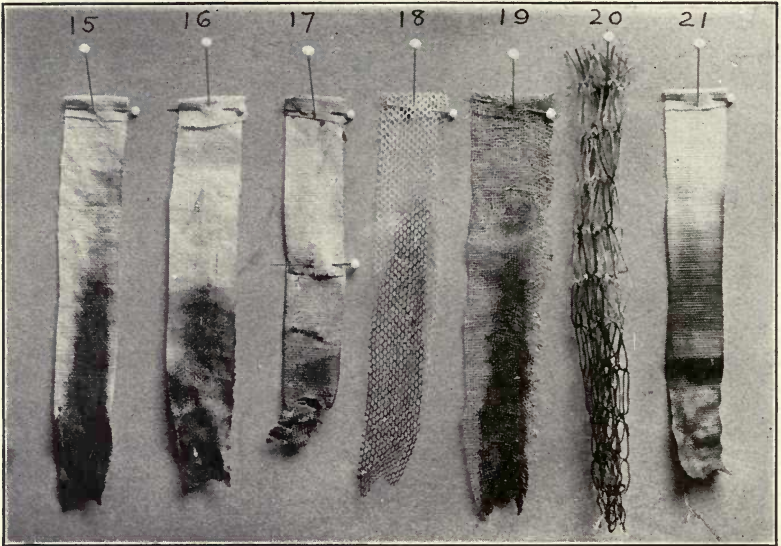

15. Ammonium Phosphate.
 16. Ammonium Sulphate.
 17. Ammonium Chloride.

18. Gauze. } Ammonium
 19. Scrim. } Phosphate.
 20. Netting. }
 21. Canvas Fireproofed in Manufacture.

FIG. 12B.

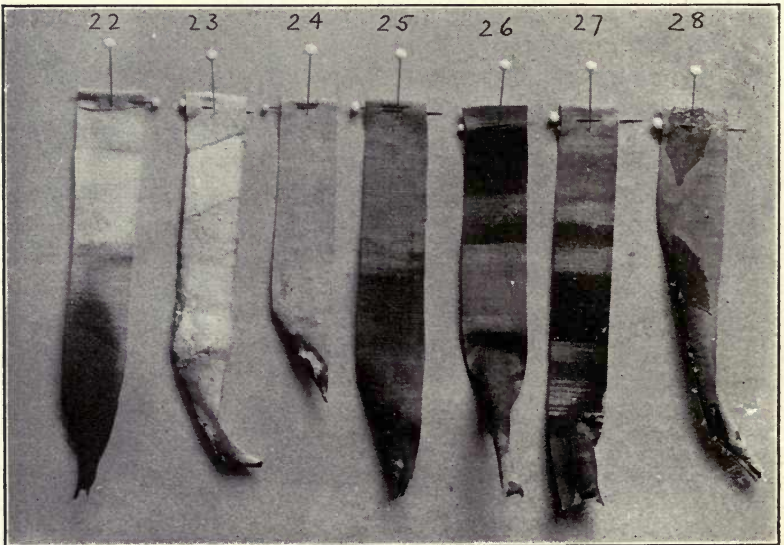

22. Blenio Solution on New Canvas.
 23. Old Scenery Treated with Electric Fireproofing Solution.
 24. " " " " Ammonium Phosphate.
 25. " " " " Solution in Chicago.
 26. " " " " Blenio Solution.
 27. " " " " Salamanderine.
 28. " " " " "No Flame."

FIG. 12C.

FLAME-PROOFED CANVAS STRIPS ONE INCH WIDE AFTER TEST OF ONE MINUTE IN ALCOHOL LAMP FLAME TWO INCHES HIGH, SHOWING COMPARATIVE EFFICIENCY OF VARIOUS "FIREPROOFING" CHEMICALS FOR PREVENTING IGNITION BY A PETTY FLAME.

through it for support. This wire, resting across the top of the chimney, supported the strip of canvas so that its lower end hung into the top of the flame for one-half an inch. The alcohol flame was kept at a constant height of two inches.

The tests of canvas made in this way corresponded in results to those made in the stovepipe, with the advantage of speed in testing and of being able to see through the glass chimney what was actually taking place. The time of a single test was one minute. The accompanying photographs, Figs. 12 to 12c, show the result of a lamp test upon canvas that had been *thoroughly impregnated* with various solutions and dried. It is doubtful if in practice scenery canvas would be so carefully impregnated with the solution, and doubtful if all the solutions would be made as strong.

This test is useful, after all, mainly for the purpose of comparing the efficiency of one method of flame-proofing treatment with another with greater precision than by the common rough test of holding a small strip of the fabric in a gas flame, and it should always be kept in mind that canvas which shows little effect of burning in this test can easily be burned to total destruction in the stovepipe test, and that *canvas which appears well fireproofed by these little single-strip, lamp-flame tests would doubtless burn with a rush of flame and suffocating smoke in a theater fire.*

For the practical purpose of seeing if the law has been complied with, and the scenery flame-proofed enough so a match, or gas jet, or electric spark will not ignite it, a simple test with a plumber's torch, or even with burning matches applied at the frayed edges and seams, in the hand of a thoroughgoing inspector will serve all practical purposes.

DRY POWDER FIRE EXTINGUISHERS.

On and about the stage of the Iroquois Theater were several tubes of Kilfyre, so-called, one of the numerous "dry powder fire extinguishers," in a long red tube, that have been so vigorously pushed into notice by enterprising salesmen during the last few years. One of the men on the stage promptly and courageously tried to extinguish the fire with this powder. The burning scenery and the fireman were not in the best positions for an extinguisher of this kind to make its best showing, and, of course, he accomplished nothing whatever, except the loss of valuable time. The fact that such unreliable material was relied on there, and is to-day hung up in public places where it gives a false sense of security, prompts me to devote some little time to this subject.

The chief reason why these long tin tubes of dry powder have become popular is that they can be manufactured for about ten cents each, and that they retail as high as \$3.00 each.

They are nearly all composed of common bicarbonate of soda (or cooking soda), frequently disguised by the admixture of a little cheap coloring matter like Venetian red, and prevented from caking by the addition of starch.

I procured a set of the U. S. patents on fire extinguishing compounds of this class and studied them for suggestions as to some more potent salt than the bicarbonate of soda, without success. In the several patents the claim for novelty generally rests on the proportion of the mixture with venetian red, yellow ochre, fullers earth, starch, etc., added to the bicarbonate of soda to prevent caking.

The party who recommended and sold these tubes of Kilfyre to the Iroquois was, I am assured, an honest man who fully believed in their efficiency, and in an effort to save others from like mistakes, I have had samples of everything of this kind that I could find in the Chicago market, the Boston market and the New York market purchased in the ordinary channels of trade by different parties, and the respective groups of samples analyzed by three different chemists, in order to fortify myself against the possibility of wronging anyone through a mistake in the analysis, and have had samples sealed up and retained for further analyses should anyone question my figures.

Fig. 13 is from a group of these extinguishers from which samples were taken for test.

Bicarbonate of soda or common cooking soda or kitchen saleratus is seen to be the principal ingredient in every case.

The bicarbonate of soda can be purchased in quantity for about one and three-fourths cents per pound. Each tube commonly contains two and one-half to three pounds. The cost of the tin box and its gorgeous label may be enough to bring the whole up

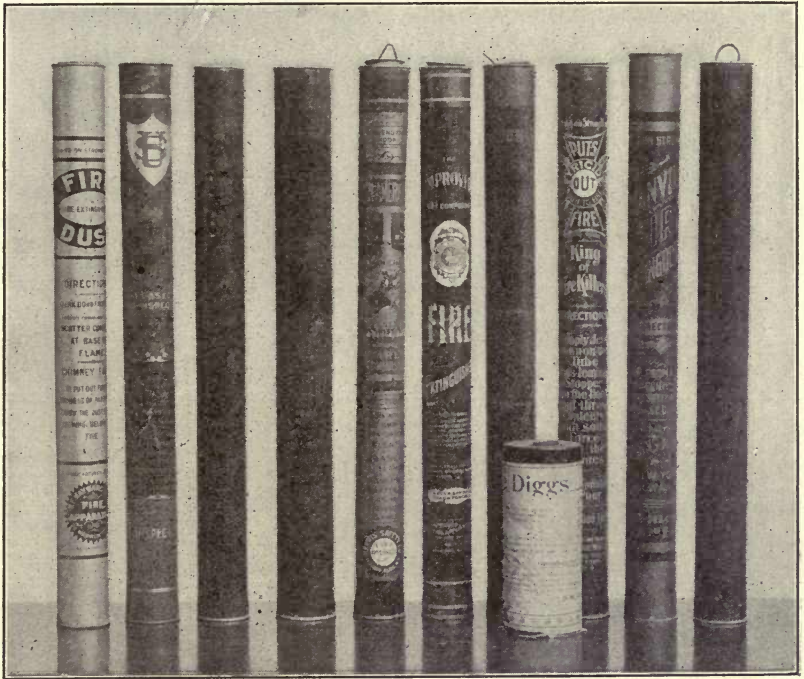

FIG. 13.—A GROUP OF DRY POWDER FIRE EXTINGUISHERS.

to ten or fifteen cents. If these are what one wants, why pay from two dollars to three dollars apiece for them? Why not buy a package of common kitchen "saleratus" at the grocer's?

I have heard remarkable stories of what they will do. Remarkable exhibitions are sometimes given under circumstances specially devised. My New York friend, the chemist, was given an exhibition by a man who poured a thin stream of benzine on the floor, lighted it and extinguished some of the powder. My friend was impressed, but did some experimenting at home and

found that after a little practice he could do the same with either sand or salt. We had tests made of two of them by our inspectors a few years ago and found them of doubtful value on the smallest fires, and worthless for a fire in free ventilation. They show up particularly well in a little fire kindled in an office spittoon.

No doubt, the material has some small value for a certain class of fires. Doubtless, it is wise to carry a few tubes of this on an automobile. Doubtless, in confined situations, on the apron of a cotton picker, even the bicarbonate of soda powder may sometimes do remarkably well, but *Dry Powder Fire Extinguishers should never be used to give a false sense of security about the stage of a theater.*

We do not recommend these tubes of dry powder in factory fire protection. We recommend they be thrown into the rubbish heap. Pails of water are far more reliable.

On the other hand, the "soda water fire extinguishers," consisting of a copper cylinder containing two, three or four gallons of a strong solution of bicarbonate of soda, with a bottle of acid at the top so arranged that it can be upset into the soda and water, thereupon generating a strong pressure by the evolution of carbonic acid gas, are excellent for many situations where pails would be unsightly.

Hand Grenades.

These are glass bottles, commonly of roughly spherical shape, and holding about a quart each of a liquid that it is claimed possesses marvellous fire extinguishing properties. I found many of these scattered about in some of the older theaters.

As showing what people will pay good money for in the effort to get fire protection, I was interested in the story that one of my agents, a chemist, in collecting samples, brought in about hand grenades. We had purchased examples of some of the different kinds of hand grenade, and had brought home a few samples that we found hanging in theaters and had their contents analyzed. In the case of particular interest, the salesman offered, as proof of the superior merits of his compound, the statement that a quantity of his particular make and style of hand grenade had just been purchased by the United States Government for the protection of one of the battleships. Our analysis shows the

contents to be simply water and common salt. I myself saw a hand grenade of the same appearance, bearing the same label, in the model of the battleship at the St. Louis exposition, so perhaps it is true that the United States government purchased salt water at fifty cents per quart bottle for the fire protection of battleships.

The chemists reported the following analyses in certain samples of hand grenades. As stated, most of these samples were old and not direct from the maker.

ANALYSIS OF CONTENTS OF "HAND GRENADE FIRE EXTINGUISHERS."

"Hayward" hand grenade, specific gravity of solution.	1.188		
common salt.....	22.3	per cent.	
other solids	0.4	" "	
"Harden" hand grenade, common salt.....	18.5	" "	
salammoniac.....	6.7	" "	
Total.....	25.5	" "	
"Babcock" hand grenade, common salt.....	21.2	" "	
chloride of calcium.	6.5	" "	
	27.7	" "	

These materials are inert, and their only advantage over plain water is that they do not freeze at ordinary winter temperatures.* The hand grenades contain about one quart of water, while a 30-cent fire-pail holds ten quarts and costs less.

I have been much interested in collecting a file of all of the patents of the United States patent office for hand grenades and fire extinguishing compounds. There are many of these patents. They are interesting reading, but I judge them more curious than useful.

A favorite line of some of the patentees has been to devise a compound apparently on the theory of finding something that would burn quicker than the surrounding fuel and thus by exhausting the oxygen smother the first fire. Other patentees propose mixtures that generate sulphurous acid and ammonia gas because of their non-support of combustion, in sublime disregard of their poisonous non-breathable quality.

Several subjects remain which we have scant time to discuss.

* For places where a non-freezing inert liquid is desired for filling fire pails probably there is nothing yet available better or cheaper than a strong solution of chloride of calcium in water. This is obtained as a by-product in the soda works of the Solvay Process Co. at Syracuse (perhaps elsewhere also), and has recently been put on the market at a low price. It is largely used for the circulating liquid in refrigerating plants.

The most important is the fire escape. I will take time only to call attention to a source of fatality that had not been foreseen until the Iroquois fire.

A FIRE-TRAP "FIRE ESCAPE."

In Fig. 14 the fire and smoke issuing from the door marked *F* ascended and enveloped the fire escape leading down from

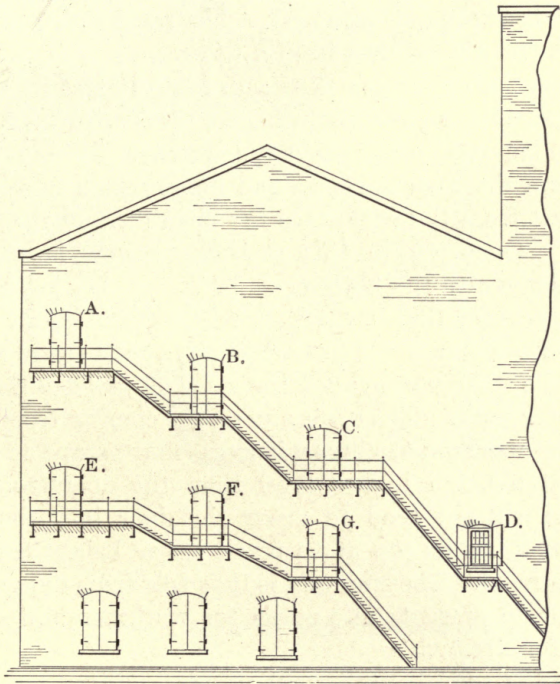

FIG. 14.—EMERGENCY EXITS IN REAR OF IROQUOIS THEATER.

A FIRE TRAP INSTEAD OF A FIRE ESCAPE. FLAMES ISSUING AT *F* CUT OFF ESCAPE FROM *A*, BY ENVELOPING GRIDIRON PLATFORM AT *B* IN FLAMES.

the upper gallery, so that many who crowded out through the doorway and stood on the upper platform at *A* could not descend, and several in their terror jumped about 40 feet to their death on the hard ground below.

I fear that in many of the theaters similar conditions could arise to-day, and this great danger of a window or doorway

underneath, through which the flames can issue and envelop the fire escape, and thus cut off its use, should be carefully looked out for.

Philadelphia Fire Escape.

A type of fire escape has been developed under the Building Laws of Philadelphia primarily for use in factories, which is so remarkably efficient and so far ahead in safety of anything else that exists that we may wonder why it has not been copied in other cities. True, it is somewhat expensive, but the safety it gives is well worth the extra cost. The same idea can be readily applied to the fire escapes from a theater.

Two varieties of this are shown in Figs. 15 and 16; one known as the Balcony type and the other as the Tower type.

The fundamental idea is that the stairway tower is absolutely cut off from the various rooms and floors which it serves. One must go out from the room into the open air and then enter the stairway. Once within this stairway tower, he can proceed without danger to the bottom.

It is to be noted that in the Tower type (Fig. 16) the free opening in the top of the tower extends close to the bottom of the floor above, while the doorways for the same story have their tops at a much lower level. Therefore, any smoke coming from an opened door of the workroom will, as it rises, find escape to the front opening at a much higher level than the door from which it issues, and will not tend to enter the door into the stairway tower, which has its top at so much lower height than the free opening in front. The stairway is thus free from danger of flame or smoke, and presents safe outlet for workmen and safe means of access for firemen.

ESCAPE FROM THE GALLERY.

The great lesson out of all the theater fires as to the danger to those in the gallery should not be forgotten in designing the stairways and fire escapes. The area, the total number of stairway exits, and the *total width of stairway per hundred persons should be two or three times as great for the gallery as for the other parts of the house*, and all exits should run in such a direct and obvious course, with guide curves instead of abrupt angles at changes of direction, that with a person once in them, he could

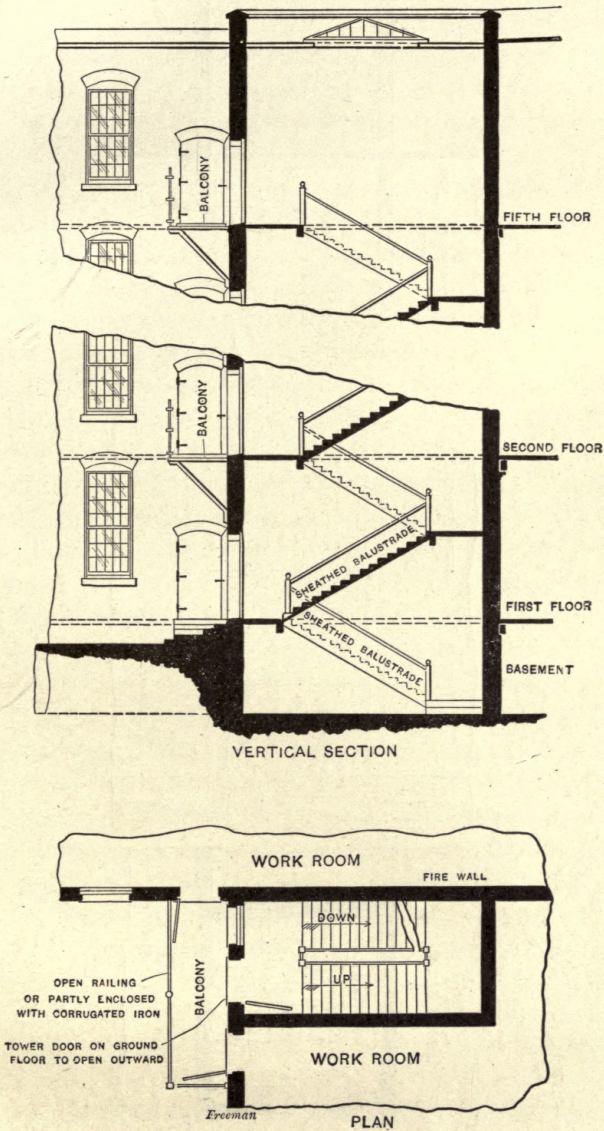

FIG. 15.—BALCONY STAIR TOWER AND FIRE ESCAPE FOR FACTORIES. PHILADELPHIA TYPE.

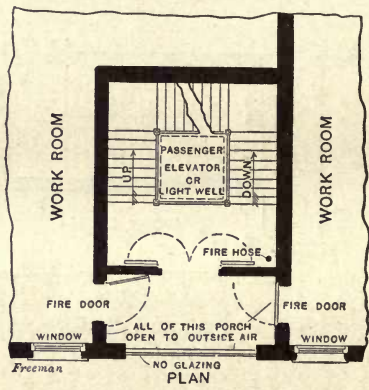
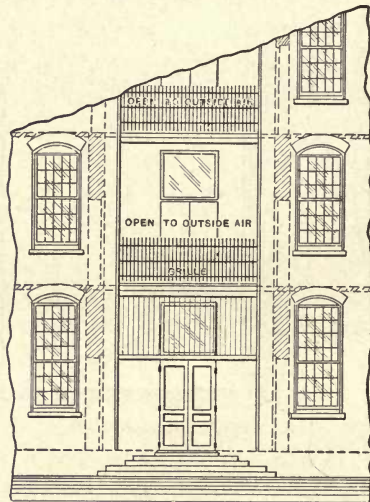
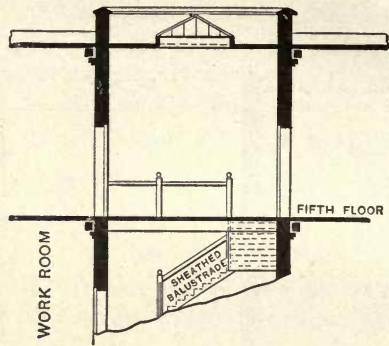

FIG. 16.—TOWER FIRE ESCAPE FOR FACTORIES.
PHILADELPHIA TYPE.

not fail to find his way to the bottom, although in total darkness. The flights of stairs should be each of the fewest steps practicable, with frequent landings on which one can steady himself, and with good, simple, continuous handrails on each side that can be followed down in darkness by sense of feeling, and a strong centre rail, continuous all the way, where wide stairs are necessary.

Width alone, as prescribed by most building laws, is not the sole consideration. The architect of the Iroquois testified that *the gallery exits of the Iroquois were of 100 per cent. greater total width than the law required.* Yet 70 per cent. of those in the Iroquois gallery perished, many at the back of the room not reaching the exits, and some in their seats.

A sad loss of many lives occurred in the Iroquois by reason of a blind passageway from the gallery, which led nowhere in particular, but which led out from the main exits in such a way that those rushing outward naturally took it as a line of escape. A few blindly located steps caused some to stumble; others tripped over them, until there was quickly a crowded and confused mass of men, women and children caught in this *cul de sac* at the top of the grand staircase hall and doomed to quick death by suffocation.

Aisles and Exits.

As to the aisles and exits, a great deal of cutting out and enlarging of aisles and removal of seats was done in theaters, in Chicago and all over the country, immediately after the Iroquois fire, apparently without reflection that *to deliver the crowd from the seats at the doorway with too great a rush increases the danger of crushing at the doors and on the stairs.* Indeed, I am of the opinion that the width of the aisles near the stage might reasonably, and with advantage, be made much narrower than the law now permits, thus increasing the number of good seats and the earning capacity of the house enough to pay good interest on the cost of making it safer and providing more numerous aisles, exits and stairways at the rear.

The narrowest aisle permitted in a theatre, even close to the stage, is commonly thirty inches. In a Pullman car and in the ordinary railway coach, twenty-two inches and twenty inches is found ample for a crowd of people moving along with all necessary speed in single file.

It is far better to introduce additional aisles at the expense of making all the aisles narrower, thus lessening the tendency, in a

mad rush, for people to try to crowd past one another, and giving better chance for those who are not strong to steady themselves by holding on with their hands to the seats on both sides the aisle as they go along toward the exit.

I was interested in timing the exit under ordinary conditions, from various representative Chicago theaters after their remodeling and was efficiently aided in this by Mr. Guy C. Shaffer, a junior architect in the office of Pond and Pond. In general we found that from the start of the curtain it was only three and a half to five minutes until the corridors were cleared, with the audience taking all the time needed for leisurely putting on wraps—ordinarily from two to three minutes sufficed for clearing balcony and gallery, and in one minute after the drop of the curtain the aisles of the main floor nearly back to the exits were commonly crowded and continued full until about two minutes after the start of the curtain. The heavy steel curtains took from fifteen seconds to thirty seconds to come down, twenty seconds being the ordinary time.

This time of leisurely emptying must not be taken as being safely sufficient for the same audience to get out if panic-stricken, for crowds may become wedged in to some of the exits and the maxim of making haste slowly may be again forgotten. At the Iroquois, under normal conditions at the close of the performance, there is no reason to think that all in this great crowd could not have found their way safely out in two and a half or three minutes, but starting panic-stricken in the midst of a performance it is different,—the door-keepers may have not opened the gates, or a hurrying crowd may take the wrong path, as to the death-trap in the Iroquois hallway and many other unthought of things are possible, such that, in the design, exits, smoke vents, and automatic sprinklers should each have full, independent, adequate attention and each be independently ready for the worst. At the Iroquois some were still struggling out when the fire chief arrived five minutes after the public alarm, and when he returned at probably nine minutes after the alarm he reports that some were still struggling down from the gallery.

Surroundings or Exposures.

Another feature that is worthy of note before closing is that *it is not essential for safety that a theater should stand in an open lot. Some of the worst theater fires in history have happened*

where the space around the theater was open on three sides or four sides.

It is far more important that attention be given to the detail of fire walls and to providing safe passageways. It should, however, always be the effort that channels of strongly arched masonry, passageways roofed almost as strongly as for a fortification, be provided running in opposite directions, so that if a fire from explosion or other unusual cause be developed in the street or along the main façade of the theater, all of the audience could easily find exit in an opposite direction to the alley or to the adjoining street.

Weekly Inspections.

In safeguarding our factories against fire, we find systematic inspections and the filing of a weekly report one of the very best means toward safety. It would be of equal value for theaters. A printed blank can readily be devised for each particular theater, or one for all the theaters of a given city. This should cover the completeness and operative condition of all valves, fire hose, sprinklers, fire-pails, soda-water extinguishers, pole-hooks, fire doors, exit locks and latches, smoke vents, fire-curtain mechanism, and particularly of the neatness, cleanliness and order of every room, passageway, closet, air chamber, loft, basement and fly gallery, used as a part of the theater building. This inspection should be made on each Monday afternoon, since the week end is the time when attractions are commonly changed and the confusion of new acts and strange properties is most apparent.

A private fire brigade from the regular stage hands and ushers should be drilled regularly, the Monday drill to be a "wet drill," testing the stage hose and a few of the soda-water extinguishers, which may be turned out of the window to the area way, or into some convenient drain provided for the purpose, at the rear of the stage.

The head stage carpenter should always be present during this performance as chief of this theater fire-brigade.

If the municipal ordinance required such reports and drills as just described, and that a duplicate of the report be filed each Monday afternoon with the public fire chief of the district, a single fireman or inspector detailed as instructor to cover in turn all the theaters of a large city would, in my judgment, accomplish more real good than the one or two stage firemen at each theater

Power—Hand, Electric Motor, Hydraulic.....	Pass'gs. Nearly vacant.
Dropped—By hand only, Automatic by melting of links.....	Storage. Floor—Wood, Incomb, hollow.....
How Used—Open and close of each performance. Each act.....	EXIT DOORS—Can make dang'rs drafts. Well protected.
As a life-saving device—Poor. Fair. Good. Excl't.	SCENERY—Am't. Small. Ordin'y. Large. Not. Fireproofed.
GENERAL.	
BOILERS—In Bkt., of Advt'm., of Stage. Outside. Not. Cut off.....	SMALL HOSE—Aud't'm. Bat. Floor. Bal'cy. Gallery.
Power—Heat, Direct, Ind'ct, Steam Pipes—safe, suspicious.....	Stage—Bat. Floor. Galleries. Gridiron.
Fans—In Attic. Well, poorly arranged.....	Fed from.....Gal. Tank.....ft. above stage roof.
PLENUM CHMB'R & Ducts—Poorly, Well out off't'm adjo't rns.	by.....In. pipe from city.....lbs. meter.....By Pump.
Contain dang's comb. Other storage. Vacant, Dirty, Clean.....	Water Supply—Poor. Fair. Good. Excl't.
ELECTRICITY—From Theatre Plant. From Public.....	AUTOMATIC SPRINKLERS—Kind.....
Switch Bd.—Wood, Incomb.—Poor. Fair. Good. Excl't.	Stage—Roof, Under gridiron, Galleries, Dress'g rms, Bat.
Gen'l Wiring.....Open.....Concl'd.....Mould'g.....	Aud't'm—Attic. Basement.....
Conduit. Poor. Fair. Good. Excl't.	Fed from.....Gal. Tank.....ft. above highest head.
Stage Lamps and Cables—Dangerous. Apr'd Types.....	from.....Gal. Press, Tank in.....lbs.
GAS—Used in Aud't'm, Dress'ng Rms, Offices.....	Wet. Dry System.....In.....
On Stage. Flames, poorly, well protected.....	Valves to Auto Spr.—All exam'd. All seal'd. All in d open.
EXIT LIGHTS—.....Oil.....Gas.....	Arrangam't Spr. Pipes—Poor. Fair. Good.
Electric—Independent. Supplied through, stage sw. bd.	PUBLIC WATER SUPPLY—Direct pump p. only. Grv'ty dlv'y.
If Ind. how connected?.....	Size st. main.....In. Supply. Poor. Fair. Good. Excl't.
FOYER LIGHTS—Elec. Gas. Ind. Sup'd, thro. stage sw. bd.	FIRE PUMP—Make.....size.....x.....x.....
If Ind. how connected?.....	Single, Duplex—Location.....
WATCHMEN—Service dur'g perf'm's. Poor. Fair. Good. Excl't.	Suction from.....ft. Supply, scant ample. Reliable.
FIRE AXES & Pote Hooks—Supply poor, good.....	Lit. Head.....ft. Supply, scant ample. Not. Safe.
THEATRE FIRE BRIGADE—Unorg'zed, Undr'd, Org'zed, Dr'd.	Power during performances—Scant. ample. Smooth, Noley.
Probable Efficiency—Poor. Doubtful. Fair. Good. Excl't.	Test.....In. str'ma.....ft. Inch. hose.
FIRE PAILS—Supply, scant, good. Neglected. Well filled.	Revs.....Press.....lbs. G. p. m.....
PORTABLE Ext'g's and Pumps—Supply scant, good. Neglected.	PUBLIC FIRE ALARM BOX—Main entrance. On stage. None.
Well cared for. Some dry powder extinguishers.....	
AS A WHOLE	
GENERAL ORDER and NEATNESS—Dang'rs. Fair. Good. Excl't.	As to Danger to Life
Extent of Auto Sprinklers—None. Scant. Tolerable. Ample.	EXPOSURE—Bad. Average. Slight. None. Bad. Average. Slight. None.
Small Hose & Perf. Ext'g's—None. Scant. Tolerable. Ample.	CONSTR'CT'N—Poor. Fair. Good. Excl't. Poor. Fair. Good. Excl't.
Water Supply Available—None. Scant. Tolerable. Ample.	OCCUPANCY—Poor. Fair. Good. Excl't. Poor. Fair. Good. Excl't.
Aid from Public Fire Dept.—None. Poor. Fair. Good.	PROTECTION—Poor. Fair. Good. Excl't. Poor. Fair. Good. Excl't.
Inspector's judgment of present conditions compared with best of class.	AS A WHOLE—Poor. Fair. Good. Excl't. Poor. Fair. Good. Excl't.

* MEANS SEE RECOMMENDATION ON SHEET ATTACHED

FIG. 17A.

THE OPINIONS EXPRESSED IN THIS REPORT ARE SIMPLY THE BEST JUDGMENTS OF THE INSPECTOR

(The inside of the double sheet is ruled and left blank for descriptive remarks under the following headings.)

Urgent for Protection of Life—

RECOMMENDATIONS.

.....
.....
.....

Urgent for Protection of Building & Contents—

.....
.....
.....

Suggestions for further improvements to make this theatre as safe as reasonable practicable without rebuilding—

.....
.....
.....

REMARKS.

.....
.....
.....

FIG. 17B.

—perhaps ten firemen in a small city or one hundred in a large city—required by law to be present from the public force, doing nothing in particular, at the expense of the theater, and who, from my factory experience, will generally be less efficient than the trained and responsible stage carpenter who is at home.

In other words, let the law emphasize fire prevention by inspection of neatness, order, and precautions more clearly.

The blank (Figs. 17, 17A and 17B on pages 160, 161 and 162) was developed by Mr. E. V. French (member of this Society and of our Mutual Engineer Corps) and myself along the lines of the Mutual Factory Inspection blank. The chief function of such a blank is to focus the attention of the inspector on the several and manifold sources of danger, and its chief virtue is in thus directing the attention of the inspector to safeguards needed and to a test of the condition of all apparatus, rather than its more apparent purpose of presenting a record of faults. The record is condensed to briefest possible compass that the statements may be more conspicuous, and we have found in

years of factory inspection that brevity in the foundation blank increases the promptness of the remedy. Seventeen Chicago theaters were inspected with this blank in hand, and it seemed to fit fairly well, although it is certain that experience can improve it. I present it here as a convenient summing up of the many points that must be continually looked out for. The condition is shown by an underscore of the word describing the condition found.

For the purpose of illustrating some of the suggestions set forth above regarding the arrangement of exit and stairways, I present on a greatly reduced scale on the pages following some carefully studied drawings that I prepared about two years ago as a means of bringing some of these matters more clearly before certain experienced theater managers, with whom I was discussing certain possible improvements. In the preparation of these plans I also had it in mind to enter a protest against some of the requirements which have been urged by eminent authorities as essential to the safety of the audience, such, for example, as that frequently urged in Europe, that a large theater or house of public entertainment ought to stand in an open lot, and as a means of showing that such arrangements for safety as proposed by the late Sir Henry Irving in his designs for a modern theater were unnecessary.

I therefore purposely assumed the difficulties of a site in the middle of a block, closely built up against on either side and open only front and rear and to the sky above. To make the illustration more complete, I also assumed a minimum width of site. The purpose is to show that the fundamental requirements for safety of the audience and safety of the fire underwriter's risk can all be adequately met on almost any kind of site, and that it is not difficult to provide far more safe and generous exit than is often found.

The drawings will set forth the proposed means of providing several exits so clearly that little description is necessary. The total seating capacity is about 1500, a large house. The points of chief interest are :

1st.—The ample exit in four different directions from the balcony and the gallery. I would call particular attention to the exits at the front corners, which have a special value in being always in sight and in front of the sitter, will tend to relieve the crush toward the rear. It was through a small inconspicuous balcony exit thus located that the family of one of my friends

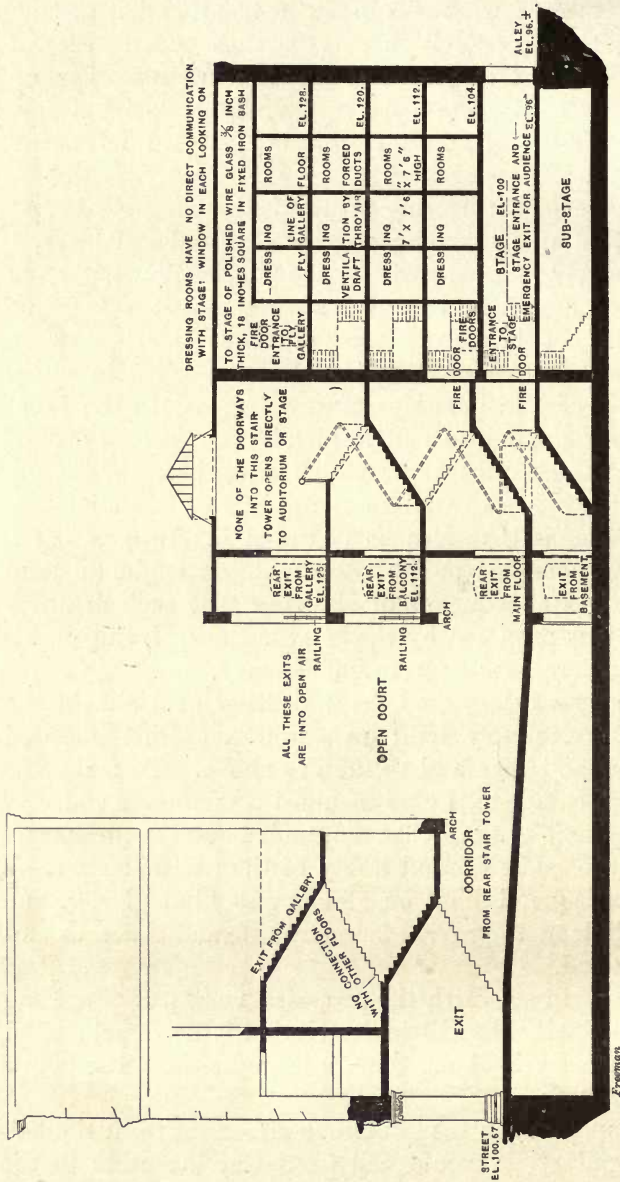

SECTION THRO' STAIR TOWERS (LEFT HAND SIDE).

Fig. 18.

Fremont

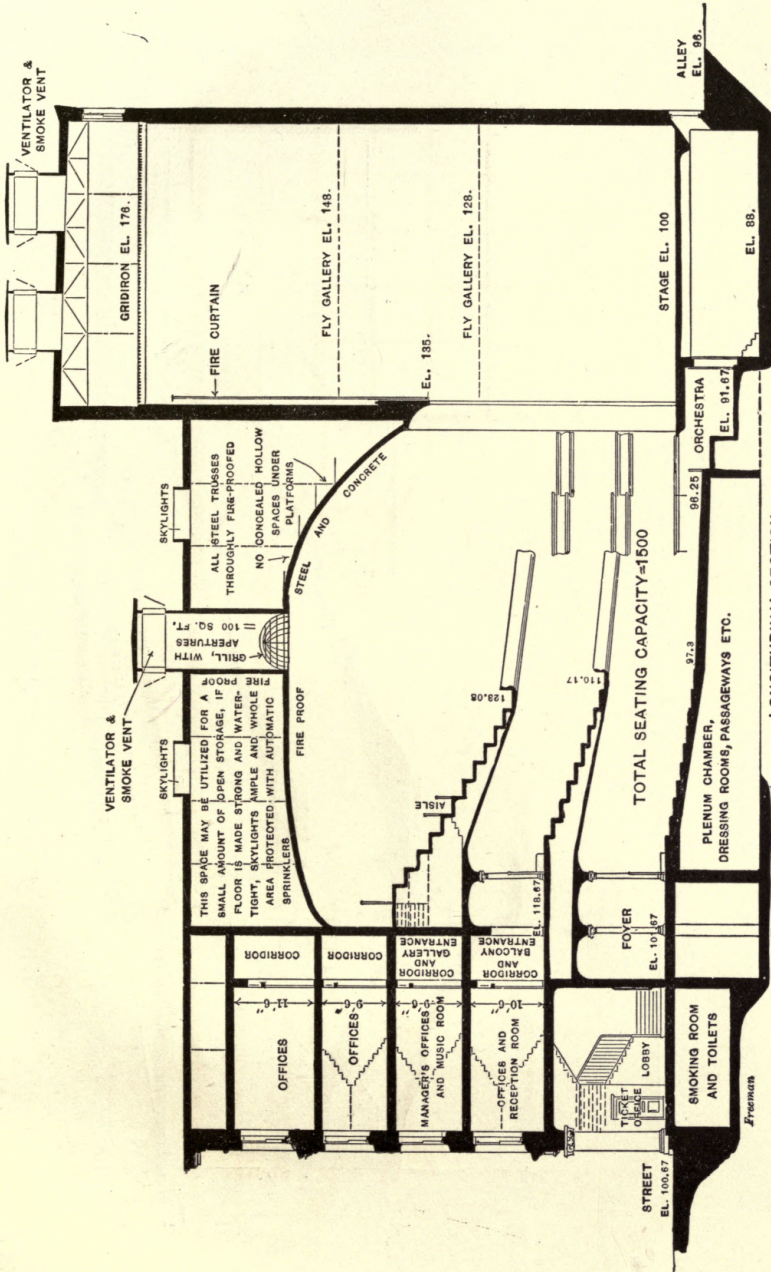

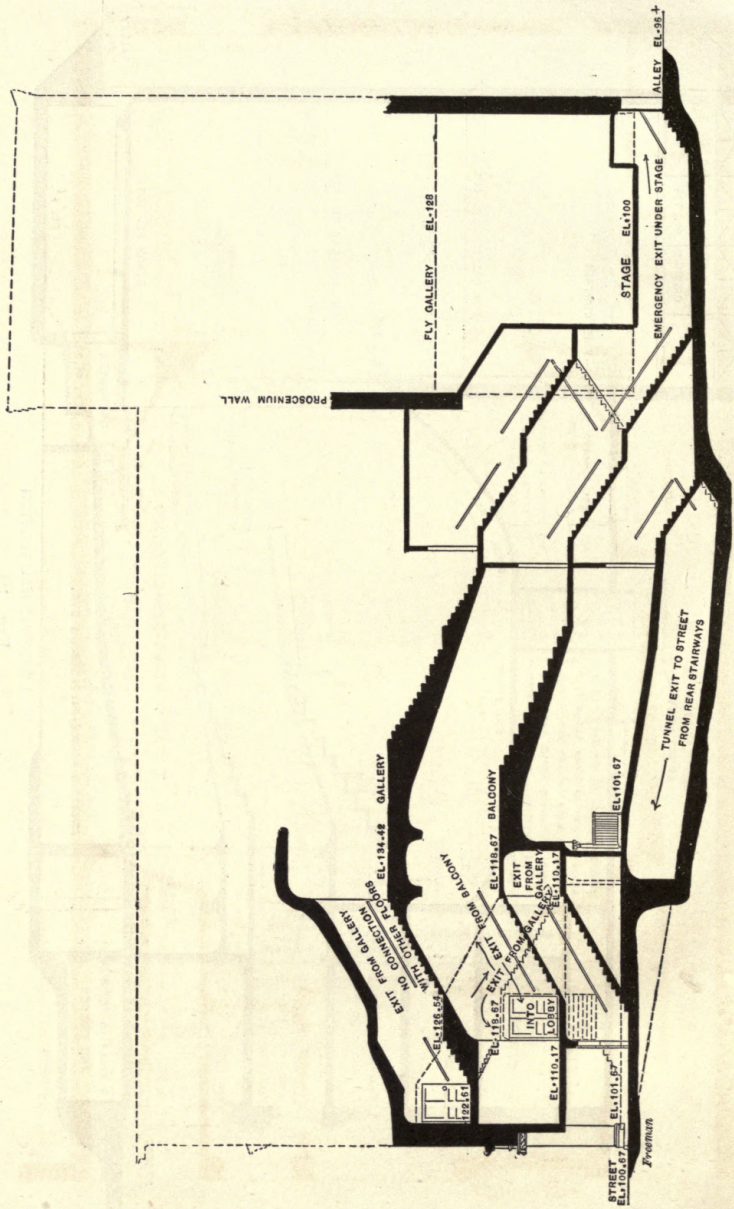

FIG. 20. —SECTION THROUGH STAIRWAY

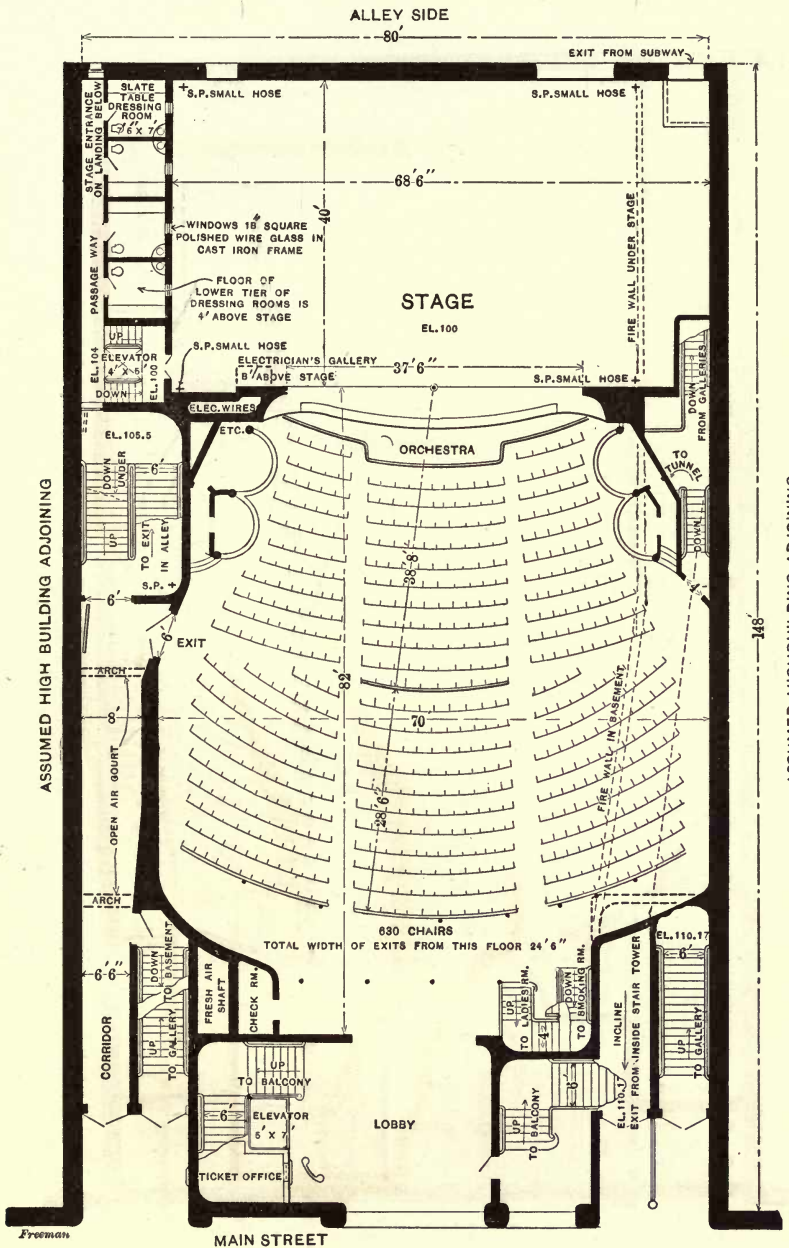
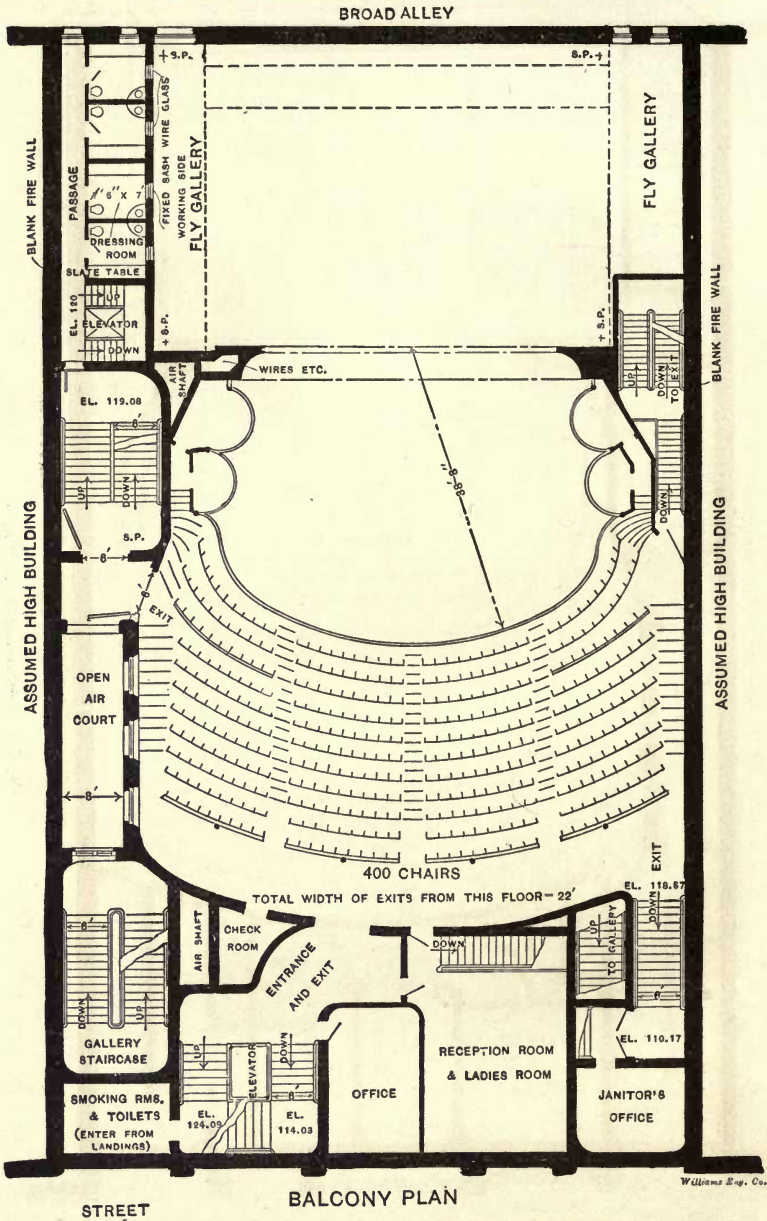

FIG. 21.--MAIN FLOOR PLAN.

AN ILLUSTRATION OF AMPLE SAFE EXITS IN DIFFICULT SURROUNDINGS.



Williams Eng. Co.

FIG. 22.—AN ILLUSTRATION OF AMPLE SAFE EXITS IN DIFFICULT SURROUNDINGS.

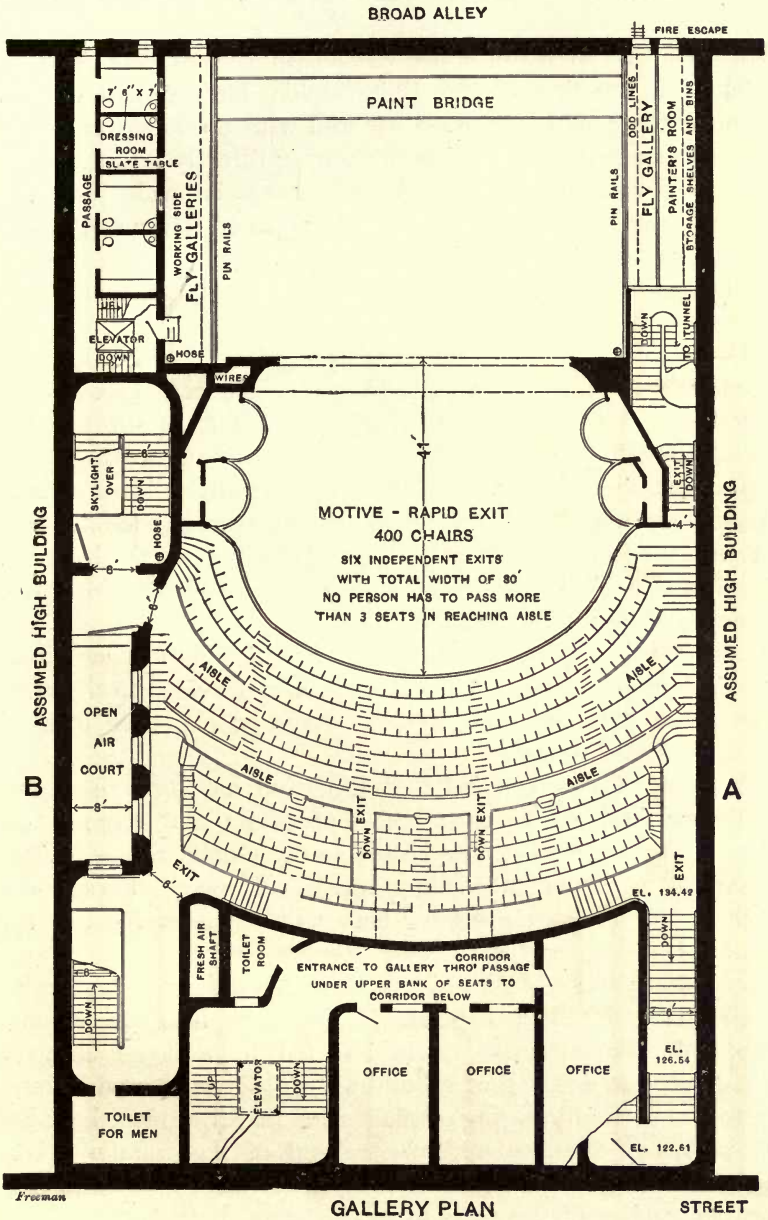

FIG. 23.—AN ILLUSTRATION OF AMPLE SAFE EXITS IN DIFFICULT SURROUNDINGS.

found their way to safety, while the crowd struggled at the rear.

2d.—The use of a tower fire escape (in the rear at the left) modeled on the line of the Philadelphia factory fire escape, communicating with the open air and with no door from auditorium or stage or dressing-room opening directly into the stair-tower proper; it being required that passage be made from the auditorium out across a platform, freely opened to the air, before the stairway can be entered.

This arrangement making it almost certain that the stairway will always be free from smoke.

3d.—Note that the stairway exits from gallery nearest the street are entirely separate from exits from other floors and serve only the gallery. To still further favor rapid exit from the gallery, two additional exits from the middle portion of the seating space drop to a corridor below, making six exits in all, and so scattered that choking about their entrances would appear impossible. As a means of separating the gallery exit from that of the balcony, I have in the spiral layout of the stairs employed a novel device analogous to a double-threaded screw.

4th.—It will also be noted that in view of the enclosed situation two ample exits of large size have been provided to the alley in the rear, for both audience and stage people, each being a sort of fireproof tunnel.

5th.—It will also be noted that provision has been made for permitting daylight to enter the auditorium and stage space, but that the windows can be closed and daylight excluded while an afternoon performance is in progress. These windows should be glazed with prism glass for better diffusion of light if the open-air court is narrow.

By making use of wire glass set in metal frames, and reinforced further by inside shutters folding back into the window jamb, and with automatic sprinklers fed by a large elevated tank, I have no doubt that a building of this type could stand safe in the path of a raging conflagration and thus meet both the best wishes of the fire underwriter and of the humanitarian. This conclusion is given in the light of what I saw in my repeated studies of the ruins after the great Baltimore fire and in the safety of the factory of the Western Electric Co.'s factory in the midst of the great San Francisco fire.

Buildings with their contents *can be made fireproof* by means of automatic sprinklers and adequate protection of the window openings.

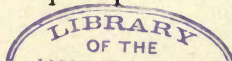

**RETURN
TO →**

LOAN PERIOD 1	2	3
4	5	6

ALL BOOKS MAY BE RECALLED AFTER 7 DAYS

DUE AS STAMPED BELOW

DUE NRLE MAR 26 1985
REC CIR JUL 26 1984

UNIVERSITY OF CALIFORNIA, BERKELEY
FORM NO. DD0, 5m, 12/80 BERKELEY, CA 94720

©s

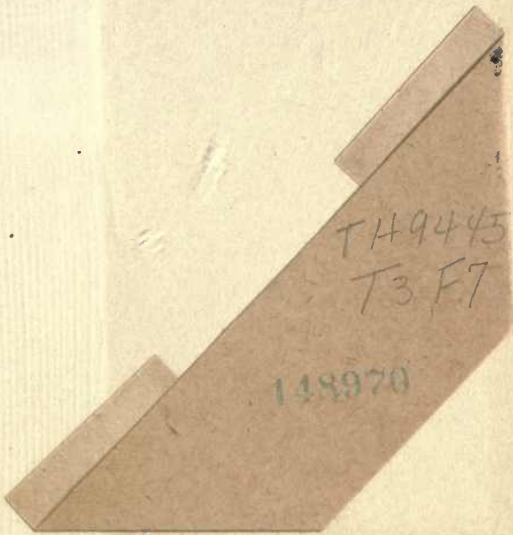

TH9445
T3 F7

148970

